

BAXI

Wall-mounted condensing boilers

LUNA HT

Installer's and User's Instructions



BAXI s.p.A., one of the leading European enterprises to produce central heating and hot water devices for domestic use (wall-mounted gas-operated boilers, floor-standing boilers, electrical water-heaters and steel heating plates) has obtained the CSQ certificate of conformity to the UNI EN ISO 9001 norms. This certificate guarantees that the Quality System applied at the **BAXI s.p.A.** factory in Bassano del Grappa, where your boiler was produced, meets the standards of the UNI EN ISO 9001 norm, which is the strictest and concerns all organization stages and operating personnel involved in the production and distribution processes.

Dear Customer,

We are sure your new boiler will comply with all your requirements.

Purchasing one of the **BAXI** products satisfies your expectations: good functioning, simplicity and ease of use.

Do not dispose of this booklet without reading it: you can find here some very useful information, which will help you to run your boiler correctly and efficiently.

Do not leave any parts of the packaging (plastic bags, polystyrene, etc.) within children's reach as they are a potential source of danger.

BAXI boilers bear the CE mark in compliance with the basic requirements as laid down in the following Directives:

- Gas Directive 90/396/CEE
- Performance Directive 92/42/CEE
- Electromagnetic Compatibility Directive 89/336/CEE
- Low Voltage Directive 73/23/CEE



Contents

Instructions pertaining to the user	Instructions prior to installation	4
	Instructions prior to commissioning	4
	Commissioning of the boiler	4
	Filling the boiler	10
	Turning off the boiler	10
	Prolonged standstill of the system. Frost protection	11
	Gas change	11
	Servicing instructions	11
Instructions pertaining to the installer	General information	12
	Instructions prior to installation	12
	Boiler installation	13
	Boiler size	13
	Fittings present in the packaging	14
	Installation of flue and air ducts	14
	Connecting the mains supply	18
	Gas change modalities	24
	Setting the boiler parameters	26
	Control and operation devices	27
	Positioning of the ignition and flame sensing electrode	28
	Check of combustion parameters	28
	Activating the flue-sweeper function	28
	Output / pump head performances	29
	How to disassemble the DHW heat exchanger	29
	Cleaning the cold water filter	30
	Annual service	30
Boiler schematic	31-32	
Illustrated wiring diagram	33-34	
Technical data	35	

Instructions pertaining to the user

- 1. Instructions prior to installation** This boiler is designed to heat water at a lower than boiling temperature at atmospheric pressure. The boiler must be connected to a central heating system and to a domestic hot water supply system in compliance with its performances and output power.
Have the boiler installed by a Qualified Service Engineer and ensure the following operations are accomplished:

-
- a) accurate purging of the whole pipework in order to remove any deposits.
 - b) careful checking that the boiler is fit for operation with the type of gas available. For more details see the notice on the packaging and the label on the appliance itself.
 - c) careful checking that the flue terminal draft is appropriate; that the terminal is not obstructed and that no other appliance exhaust gases are expelled through the same flue duct, unless the flue is especially designed to collect the exhaust gas coming from more than one appliance, in conformity with the laws and regulations in force.
 - d) careful checking that, in case the flue has been connected to pre-existing flue ducts, thorough cleaning has been carried out in that residual combustion products may come off during operation of the boiler and obstruct the flue duct.

- 2. Instructions prior to commissioning** Initial lighting of the boiler must be carried out by a licensed technician. Ensure the following operations are carried out:
- a) compliance of boiler parameters with (electricity, water, gas) supply systems settings.
 - b) compliance of installation with the laws and regulations in force.
 - c) appropriate connection to the power supply and grounding of the appliance.
- The names of authorized Service Centres are listed on the accompanying sheet.
Failure to observe the above will render the guarantee null and void.
Prior to commissioning remove the protective plastic coating from the unit. Do not use any tools or abrasive detergents as you may spoil the painted surfaces.

- 3. Commissioning of the boiler** To correctly light the burner proceed as follows:
- 1) provide power supply to the boiler;
 - 2) open the gas cock;
 - 3) follow the directions given below regarding the adjustments to be made at the boiler control panel.

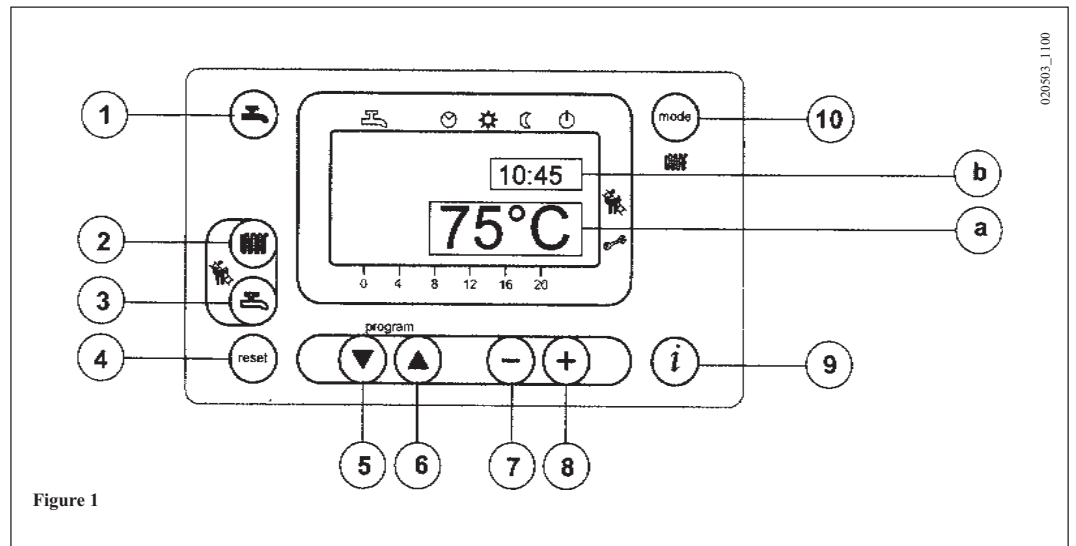























Figure 1

KEYS

DISPLAY SYMBOLS







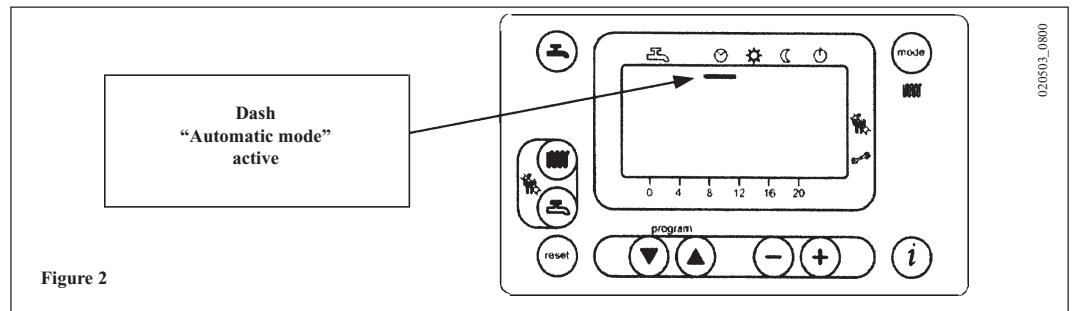

- | | |
|---|--|
|  Domestic hot water on/off key |  Operation in domestic hot water mode |
|  Central heating water temperature setting key |  Operation in central heating mode |
|  Domestic hot water temperature setting key |  Operation in automatic mode |
|  Reset key |  Operation in manual mode at the maximum temperature set |
|  Program access and scroll keys |  Operation in manual mode at minimum temperature |
|  Program access and scroll key |  Standby (off) |
|  Parameter setting key (decrease value) |  Outdoor temperature |
|  Parameter setting key (increase value) |  Flame present (on) |
|  Data display reset key |  Resettable alarm warning |
|  Central heating mode setting key | a) MAIN display |
| | b) SECONDARY display |

3.1 Description of keys



-  (2) This key can be pressed to set the central heating water output temperature as described in point 3-3.
-  (3) This key can be pressed to set the domestic hot water temperature as described in point 3-4.
-  **(10) Central heating mode operating key**

The  key can be pressed to activate four boiler central heating operating modes; these modes are identified by a black cursor line underneath the relative symbol on the display, and are as follows:







- a) ☺ Automatic operation.** Operation of the boiler is controlled by the timed program as described in point 3-5.1 “Daily timed program for operation of the central heating system”;
- b) ⚙ Manual operation at the maximum temperature set.** The boiler comes into operation regardless of the timed program set. The operating temperature is that set using the  key (point 3-3: “Setting the maximum central heating temperature”);
- c) ☾ Manual operation at minimum temperature.** The operating temperature is that set in point 3-6: “setting the minimum central heating temperature”.
- d) ⏻ standby.** The boiler does not work in central heating mode, although the antifreeze function is still enabled.
-  **(1) Domestic hot water on/off key:** This key can be pressed to activate or deactivate this function, which is identified on the display by a black cursor line under the symbol .
-  **(4) Reset key.** In case of a fault, referred to in point 3-7 “Faults and resetting the boiler”, the boiler can be restarted by pressing this key for at least two seconds. If this key is pressed with no fault present, the display will show the message “E153”, and the same key has to be pressed again (for at least two seconds) to restart the boiler.
-  **(9) Data key.** This key can be pressed repeatedly to display the following information:
- Temperature (°C) of the domestic hot water ();
 - outdoor temperature (°C) (); only provided with the outdoor temperature sensor probe connected.
- Press either of the  (mode) keys to return to the main menu.

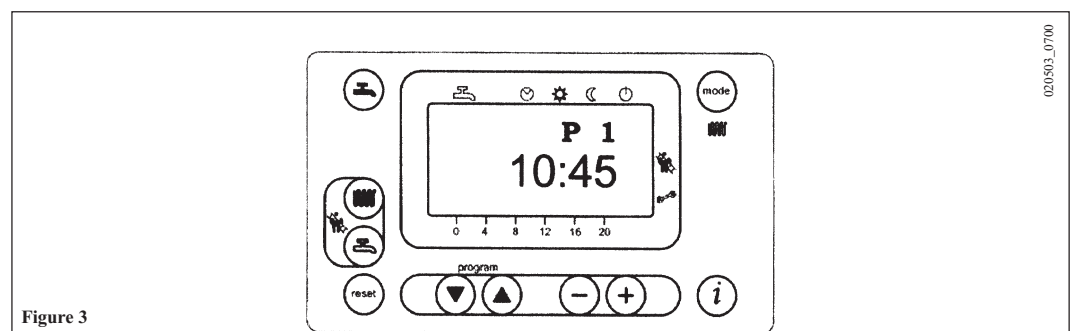



3-2. Setting the time



- a)** Press either of the   keys to access the programming function; the display will show the letter P followed by a number (program line);







- b) press the   keys until the display shows P1, referring to the time to be set;
- c) press the   keys to set the time; on the display, the letter P will start to flash;
- d) press the  key to save and exit the programming function;

3-3 – Setting the maximum central heating temperature

- Press the  key (2-figure 1) to set the central heating water temperature;
- Press the   keys to set the temperature required;
- press either of the   keys (1 or 10 - figure 1) to save and return to the main menu.







N.b – With the outdoor sensor probe connected, the  key (2 - figure 1) can be used to shift the central heating curve. Press the   keys to decrease or increase the room temperature in the premises to be heated.

3-4 Setting the maximum domestic hot water temperature

- Press the  key (3-figure 1) to set the maximum domestic hot water temperature;
- Press the   keys to set the temperature required;
- press either of the   keys (1 or 10 - figure 1) to save and return to the main menu.

3-5– Setting the daily program for operation in central heating and domestic hot water modes





3-5.1 Setting the daily times for central heating mode operation

- Press either of the   keys to access the programming function;
 - a) press these keys until the display shows P11, referring to the program start time;
 - b) press the   keys to set the time;
- press the  key; the display will show P12, referring to the program end time;
- repeat the operations described in points a and b until the third and last cycle is reached (program line P16);
- press the  key to save and exit from the programming function.

3-5.2 Setting the daily times for domestic hot water mode operation

- Carry out the operations described in point 3-5.1 for program lines 31 to 36.



3-6 - Setting the minimum central heating temperature

- press either of the   keys to access the programming function;
- press these keys until the display shows P5, referring to the temperature to be set;
- press the   keys to set the temperature required.

This operating mode is enabled when minimum temperature central heating mode “” is activated or when the daily central heating program does not require heat.

N.b – With the outdoor sensor probe connected, parameter P5 can be used to set the minimum room temperature in the premises to be heated.

3-7 - Table of user-settable parameters

Parameter N.	Parameter description	Factory setting	Range
P1	Time of day setting	————	0...23:59
P5	Minimum central heating temperature setting (°C)	25	25..80
P11	Start of first daily period of automatic central heating	6:00	00:00...24:00
P12	End of first daily period of automatic central heating	22:00	00:00...24:00
P13	Start of second daily period of automatic central heating	0:00	00:00...24:00
P14	End of second daily period of automatic central heating	0:00	00:00...24:00
P15	Start of third daily period of automatic heating	0:00	00:00...24:00
P16	End of third daily period of automatic central heating	0:00	00:00...24:00
P31	Start of first daily period of domestic hot water production	0:00	00:00...24:00
P32	End of first daily period of domestic hot water production	24:00	00:00...24:00
P33	Start of second daily period of domestic hot water production	0:00	00:00...24:00
P34	End of second daily period of domestic hot water production	0:00	00:00...24:00
P35	Start of third daily period of domestic hot water production	0:00	00:00...24:00
P36	Fine End of third daily period of domestic hot water production	0:00	00:00...24:00
P45	Reset of daily central heating and domestic hot water production programs (factory settings). Press the - + keys together for about 3 seconds; the number 1 appears on the display. Confirm by pressing either of the   keys	0	0...1
P516	Temperature for automatic switching from SUMMER to WINTER modes with outdoor temperature probe connected. When this temperature value is set, the boiler automatically switches from summer to winter mode when the outdoor sensor detects an average temperature value, calculated over 24 hours, higher than the set point.	20	8...30
P532	HC1 circuit heating curve gradient (parameter for the installation engineer).	15	1 ... 40
P533	HC2 circuit heating curve gradient (parameter for the installation engineer).	15	1 ... 40
P534	HC1 circuit parallel shift (parameter for the installation engineer).	0	-31 ... 31 K
P535	HC2 circuit parallel shift (parameter for the installation engineer).	0	-31 ... 31 K

3-8 - Fault warnings and resetting the boiler

If a fault occurs, a flashing warning code appears on the display.

The fault warnings appear on the main display (figure 1 a) together with the  symbol (Figure 4).

To reset, press the reset  button for at least two seconds.

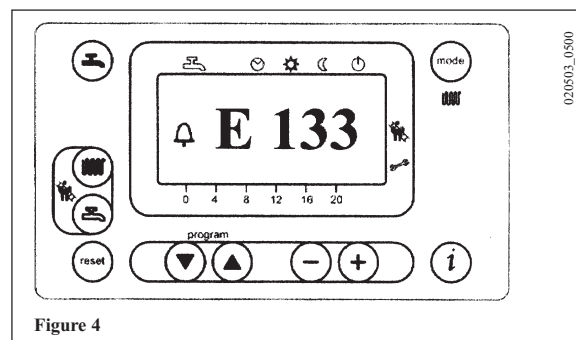

Figure 4

Fault warnings appear on the secondary display (figure 1 b) alternating with the time, both of them flashing (figure 4.1). It is not possible to reset malfunction warnings which appear on the secondary display as the cause of the alarm has first to be removed.

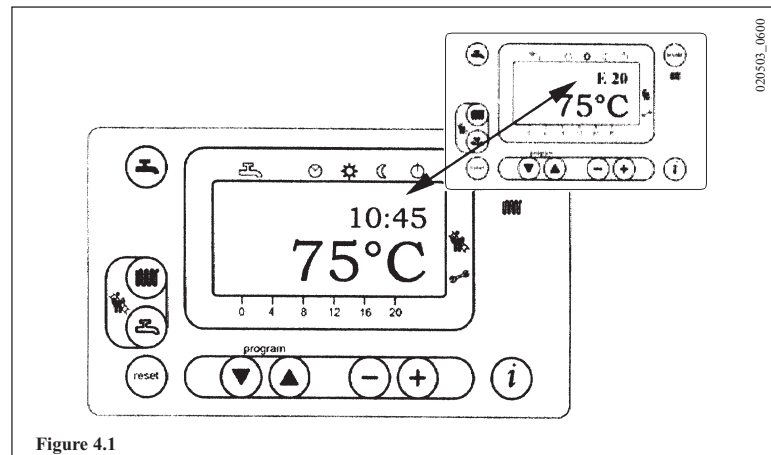

Figure 4.1

3.9 Fault warnings table

Fault code	Fault description	action required
10	outdoor temperature probe sensor failure	call the authorised service centre.
20	ntc output sensor failure	call the authorised service centre
50	domestic hot water ntc sensor failure	call the authorised service centre
110	safety or flue gas thermostat tripped	press the reset key (for about 2 seconds: if this device is triggered repeatedly, call the authorised service centre)
132	floor thermostat tripped	call the authorised service centre
133	no gas	press the reset key (for about 2 seconds); if the fault persists, call the authorised service centre)
135	fan electricity supply failure	call the authorised service centre
151	boiler circuit board error	switch off the electricity supply to the boiler for 10 seconds; if the fault persists, call the authorised service centre)
153	the reset key has been pressed inappropriately	press the key again (about 2 seconds)
154	internal error on boiler circuit module	Press and hold reset button (2 seconds approx.) then press again when warning E153 appears
160	fan speed threshold not reached	call the authorised service centre.
164	no hydraulic differential pressure switch enabling signal	check that the system is at the rated pressure. (refer to the section on filling the system). if the fault persists, call the authorised service centre.
183	saving parameters	If the warning is displayed for more than 3 seconds, press and hold the reset button (2 seconds approx.) then press again when the warning E153 appears

All the faults are displayed in order of importance; if several faults occur simultaneously, the first to be displayed is the one with highest priority. After the cause of the first fault has been removed, the second one will be displayed, and so on.

If any given fault occurs frequently, contact the authorised Service Centre.

- 4. Filling the boiler** Important: Regularly check that the pressure displayed by the pressure gauge (11) is 1 to 1.5 bar, with boiler not operating. In case of overpressure, open the boiler drain valve. In case the pressure is lower open the boiler filling tap (Figure 5a or 5b). We recommend you open the tap very slowly in order to let off the air. In case pressure drops occur frequently have the boiler checked by a Qualified Service Engineer.

LUNA HT 280 - HT 330

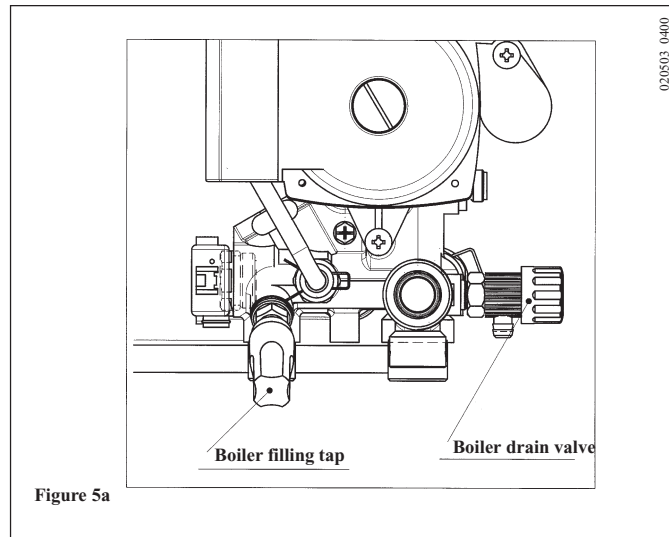

LUNA HT 1.120 - HT 1.240 - HT 1.280

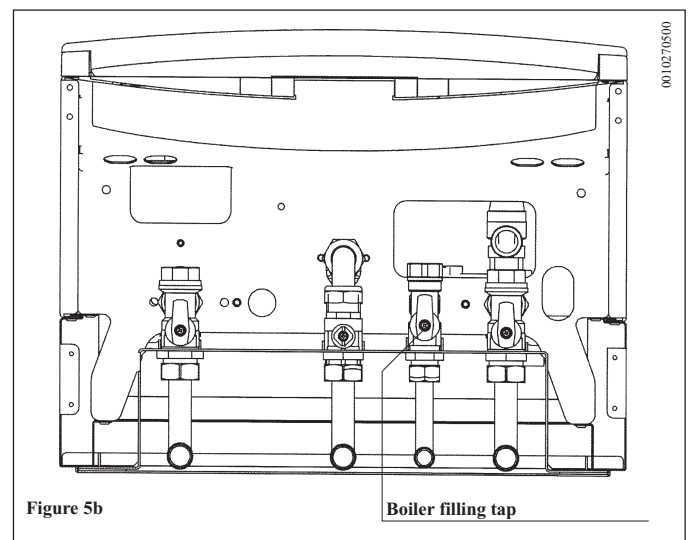

The boiler is equipped with a hydraulic differential pressure switch that will inhibit the operation of the boiler in the event of the pump seizing or running dry.

- 5. Turning off the boiler** To shut down the boiler switch off the electrical supply to the appliance.

6. Prolonged standstill of the system. Frost protection We recommend you avoid draining the whole system as water replacements engender purposeless and harmful limestone deposits inside the boiler and on the heating elements.
In case the boiler is not operated during wintertime and is therefore exposed to danger of frost we suggest you add some specific-purpose anti-freeze to the water contained in the system (e.g.: propylene glycole coupled with corrosion and scaling inhibitors).
The electronic management of boilers includes a 'frost protection' function in the central heating system which operates the burner to reach a heating flow temperature of 30° C when the system heating flow temperature drops below 5°C.

The frost protection function is enabled if:

- * electrical supply to the boiler is on;
- * the gas service cock is open;
- * the system pressure is as required;
- * the boiler is not blocked.

7. Gas change These boilers produced for natural gas can be converted to work with LPG.
Any gas change must be effected by a Qualified Service Engineer.

8. Servicing instructions To maintain efficient and safe operation of your boiler have it checked by a Qualified Service Engineer at the end of every operating period.
Careful servicing will ensure economical operation of the system.
Do not clean the outer casing of the appliance with abrasive, aggressive and/or easily flammable cleaners (i.e.: gasoline, alcohol, and so on). Always isolate the electrical supply to the appliance before cleaning it (see section Turning off the boiler on page 10).

Instructions pertaining to the installer

9. General information The following remarks and instructions are addressed to Service Engineers to help them carry out a faultless installation. Instructions regarding lighting and operation of the boiler are contained in the 'Instructions pertaining to the user' section.

Note that installation, maintenance and operation of the domestic gas appliances must be performed exclusively by qualified personnel in compliance with current standards.

Please note the following:

- * This boiler can be connected to any type of double- or single feeding pipe convector plates, radiators, thermoconvectors. Design the system sections as usual though taking into account the available output / pump head performances, as shown on page 29.
- * Do not leave any packaging components (plastic bags, polystyrene, etc.) within children's reach as they are a potential source of danger.
- * Initial lighting of the boiler must be effected by a Qualified Service Engineer.

Failure to observe the above will render the guarantee null and void.

10. Instructions prior to installation This boiler is designed to heat water at a lower than boiling temperature at atmospheric pressure. The boiler must be connected to a central heating system and, on models with this option, to a domestic hot water supply system in compliance with its performances and output power.

Before connecting the boiler have the following operations effected:

- a) careful checking that the boiler is fit for operation with the type of gas available. For more details see the notice on the packaging and the label on the appliance itself.

- b) careful checking that the flue terminal draft is appropriate; that the terminal is not obstructed and that no other appliance exhaust gases are expelled through the same flue duct, unless the flue is especially designed to collect the exhaust gase coming from more than one appliance, in conformity with the laws and regulations in force.

- c) careful checking that, in case the flue has been connected to pre-existing flue ducts, thorough cleaning has been carried out in that residual combustion products may come off during operation of the boiler and obstruct the flue duct.

To ensure correct operation of the appliance and avoid invalidating the guarantee, observe the following precautions

1. Hot water circuit:

if the water hardness is greater than 20 °F (1 °F = 10 mg calcium carbonate per litre of water) install a polyphosphate or comparable treatment system responding to current regulations.

2. Heating circuit

2.1. new system

Before proceeding with installation of the boiler, the system must be cleaned and flushed out thoroughly to eliminate residual thread-cutting swarf, solder and solvents if any, using suitable proprietary products.

2.2. existing system:

Before proceeding with installation of the boiler, the system must be cleaned and flushed out to remove sludge and contaminants, using suitable proprietary products.

To avoid damaging metal, plastic and rubber parts, use only neutral cleaners, i.e. non-acid and non-alkaline (e.g. SENTINEL X400 and X100), proceeding strictly in accordance with the maker's

directions.

Remember that the presence of foreign matter in the heating system can adversely affect the operation of the boiler (e.g. overheating and noisy operation of the heat exchanger)

11. Boiler installation Decide upon the boiler location, then tape the template on the wall.

Connect the pipework to the gas and water inlets prearranged on the template lower bar. If you are either installing the boiler on a pre-existent system or substituting it, we suggest you also fit settling tanks on the system return pipework and under the boiler to collect the deposits and scaling which may remain and be circulated in the system after the purge. When the boiler is fixed on the template connect the flue and air ducts (fittings supplied by the manufacturer) according to the instructions given in the following sections. Connect the condensate outlet to the siphon supplied with the boiler. Connect the siphon to a drain, making sure there is a continuous slope. Horizontal sections must be avoided.

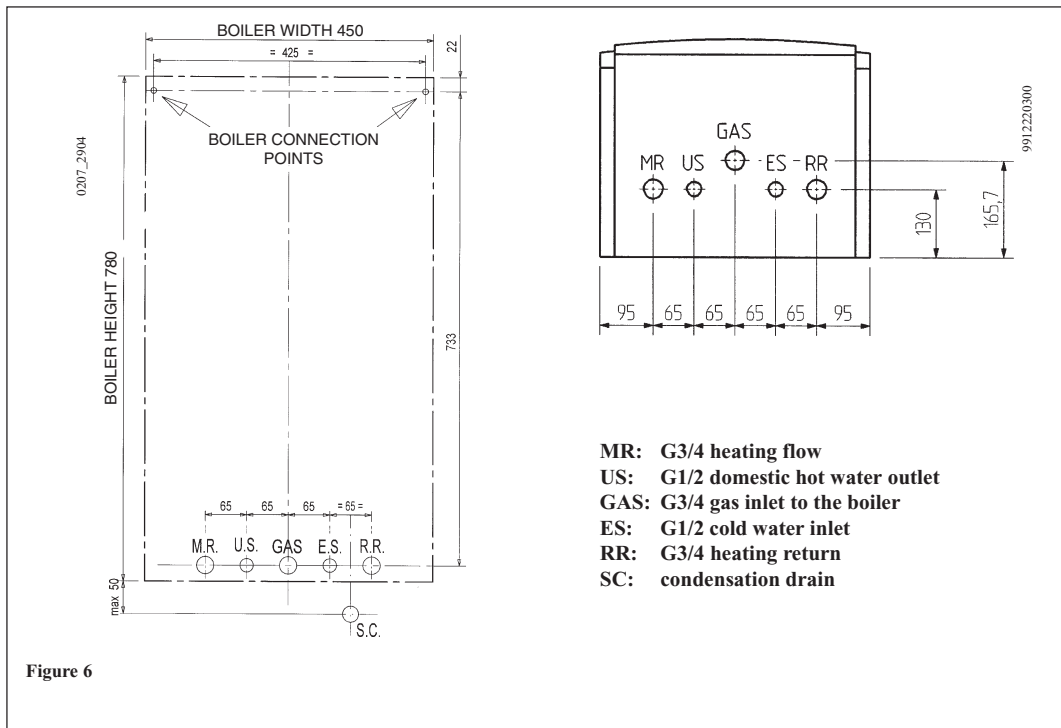

12. Boiler size

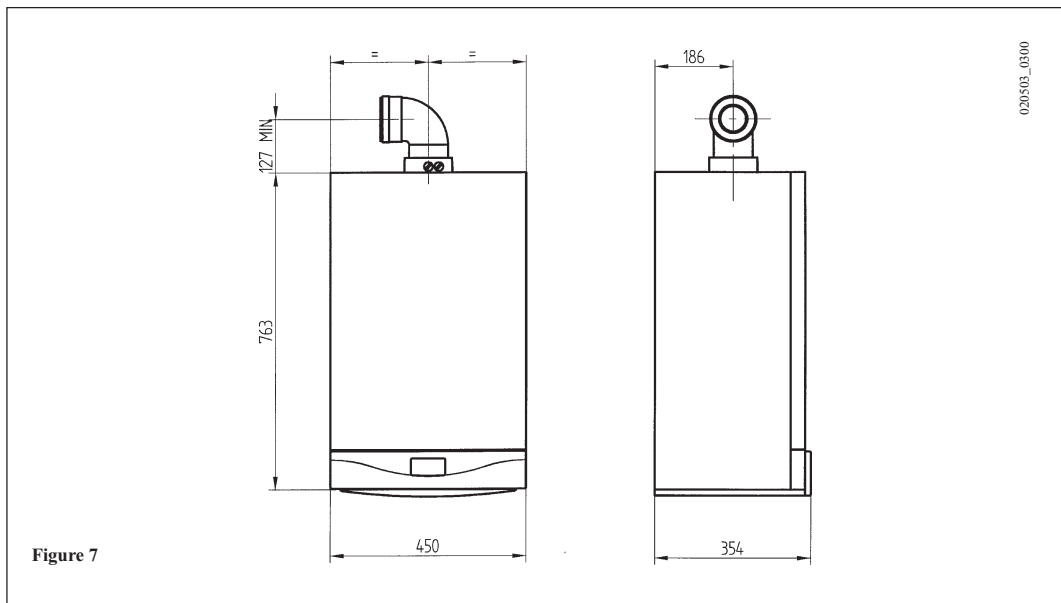

- 13. Fittings present in the packaging**
- template
 - gas cock (16)
 - inlet water tap with filter (17)
 - heating system delivery cock (19)
 - heating system return cock (18)
 - washers
 - telescopic tubes
 - screws and wall plugs

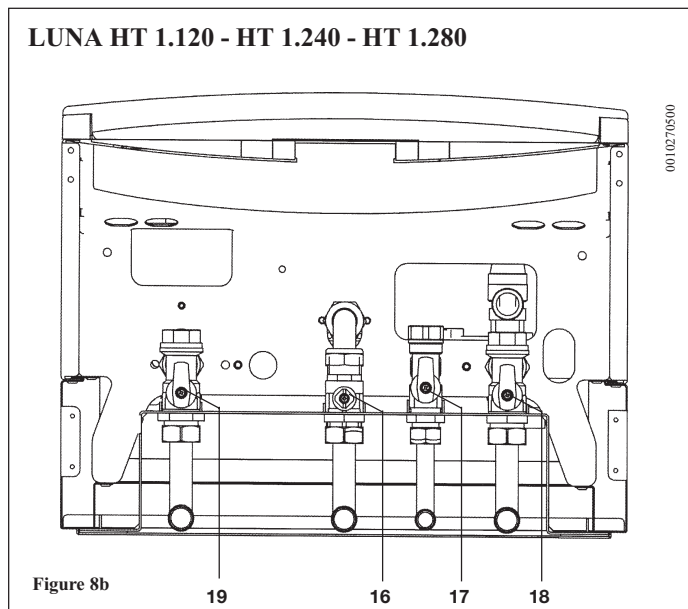
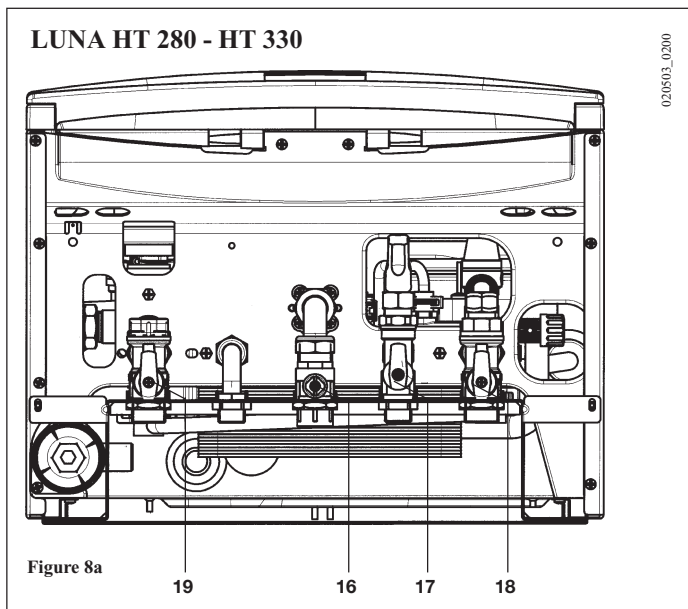

14. Installation of flue and air ducts We guarantee ease and flexibility of installation for a gas-fired forced draft boiler thanks to the fittings and fixtures supplied (described below).
 The boiler is especially designed for connection to an exhaust flue / air ducting, with either coaxial, vertical or horizontal terminal. By means of a splitting kit a two-pipe system may also be installed.
In case exhaust and intake flues not supplied by BAXI S.p.A. have been installed, these must be certified for the type of use and must have a maximum pressure drop of 100 Pa.

Warnings for the following types of installation:

- C₁₃, C₃₃ The terminals for the split flue must be provided for within a square with 50 cm sides. Detailed instructions are given together with each accessory.
- C₅₃ The terminals for combustion air intake and for the expulsion of combustion products must not be provided for on opposite walls of the building.
- C₆₃ The maximum pressure drop of the ducts must not exceed 100 Pa. The ducts must be certified for the specific use and for a temperature of over 100°C. The chimney flue must be certified in accordance with the prEN 1856-1 Regulation.
- C₄₃, C₈₃ The chimney or flue used must be suitable for the use.

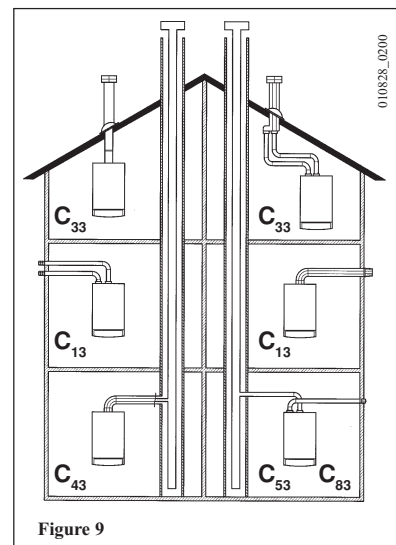

Flue duct terminal	Max. length of flue duct	Each 90° bend reduces the duct max. length by	Each 45° bend reduces the duct max. length by	Flue terminal diameter	Outer terminal diameter
Coaxial Ø 60/100 mm	10 m	1 m	0,5 m	100 mm	100 mm
Vertical two-pipe	15 m	0,5 m	0,25 m	133 mm	80 mm
Horizontal two-pipe	80 m	0,5 m	0,25 m	-	80 mm

... coaxial flue - air duct (concentric)

This type of duct allows to disengage exhaust gases and to draw combustion air both outside the building and in case a LAS flue is fitted. The 90° coaxial bend allows to connect the boiler to a flue-air duct in any direction as it can rotate by 360°. It can moreover be used as a supplementary bend and be coupled with a coaxial duct or a 45° bend.

If the flue outlet is placed outside, the flue-air ducting must protrude at least 18mm out of the wall to allow aluminium weathering tile to be fitted and sealed to avoid water leakages.

Ensure a minimum downward slope of 1 cm towards the outside per each metre of duct length.

A 90° bend reduces the total duct length by 1 metre.
A 45° bend reduces the total duct length by 0.5 metre.

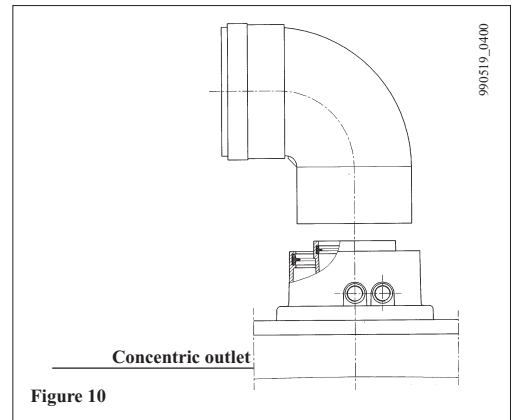
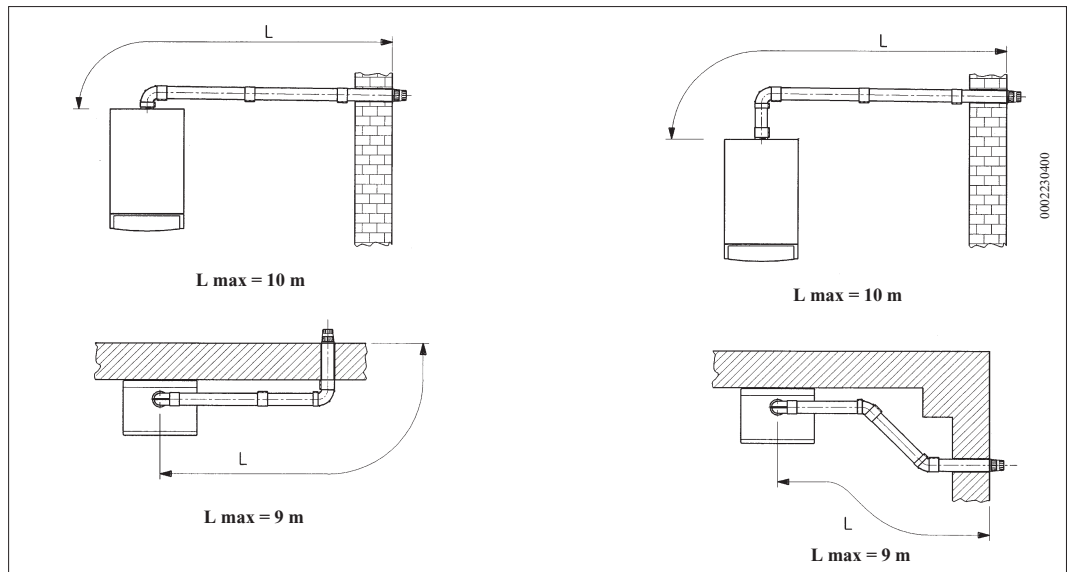
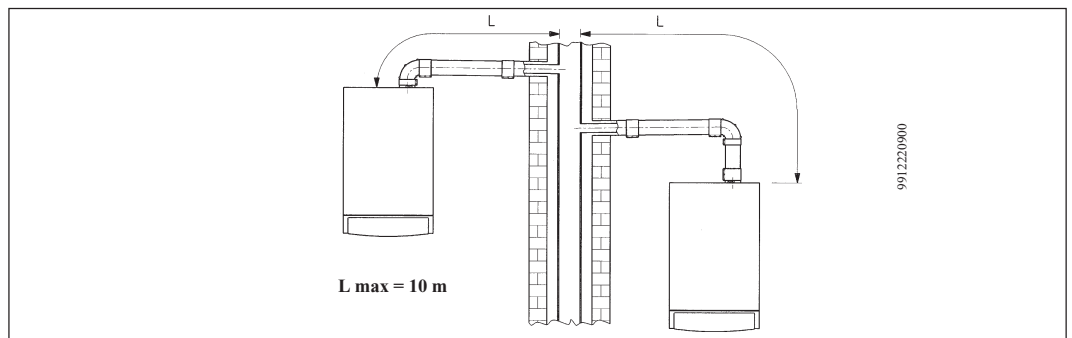

Figure 10

Horizontal flue terminal Ø 60/100 mm installation options



LAS flue duct Ø 60/100 mm installation options



Vertical flue terminal Ø 60/100 mm installation options

This type of installation can be carried out both on a flat or pitched roof by fitting a terminal, an appropriate weathering tile and sleeve, (supplementary fittings supplied on demand).

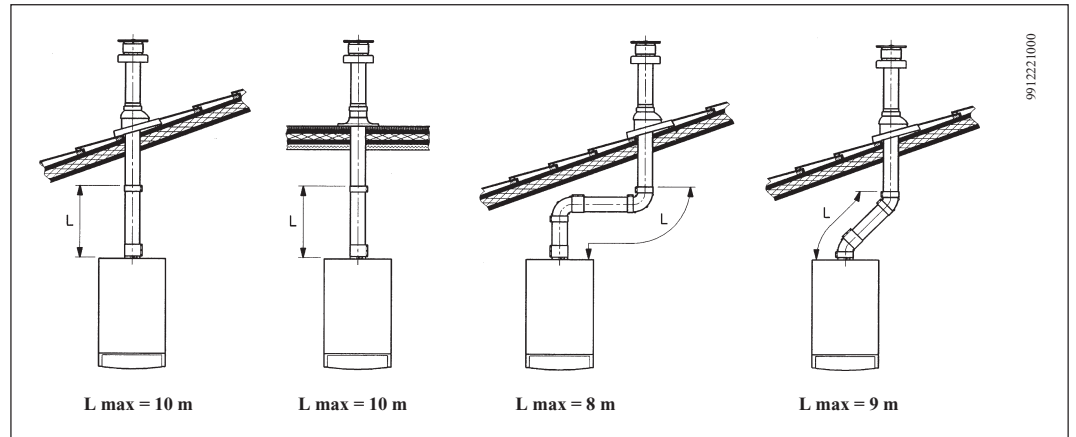

... separated flue-air ducting

This type of ducting allows to disengage exhaust flue gases both outside the building and into single flue ducts.

Comburent air may be drawn in at a different site from where the flue terminal is located.

The splitting kit consists of a flue duct adaptor (100/80) and of an air duct adaptor.

For the air duct adaptor fit the screws and seals previously removed from the cap.

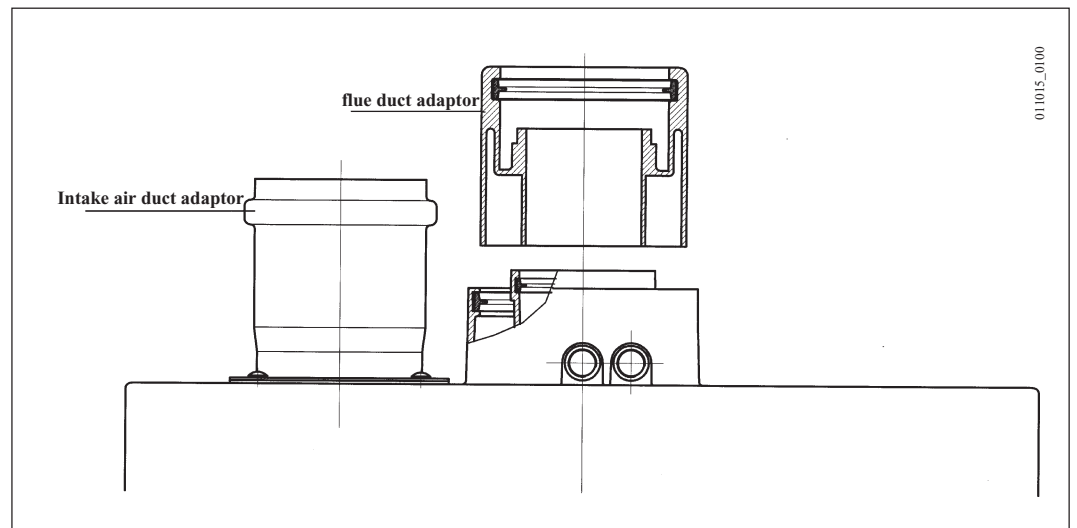

The 90° bend allows to connect the boiler to flue-air ducting regardless of direction as it can be rotated by 360°. It can moreover be used as a supplementary bend to be coupled with the duct or with a 45° bend.

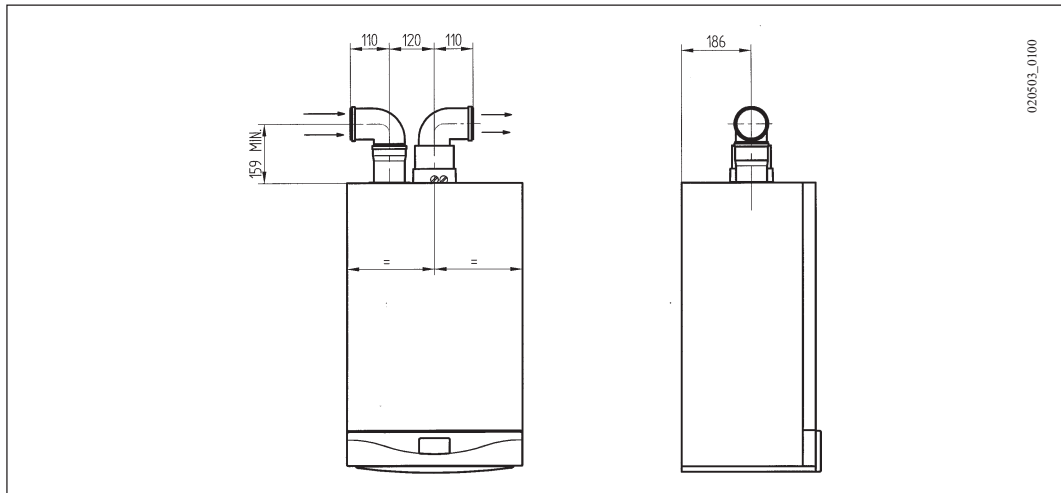

A 90° bend reduces the total duct length by 0.5 metre.
 A 45° bend reduces the total duct length by 0.25 metre.

Separated horizontal flue terminals installation options

IMPORTANT: Ensure a minimum downward slope of 1 cm toward the outside per each metre of duct length

Make sure that the exhaust and intake ducts are securely fixed to the walls.

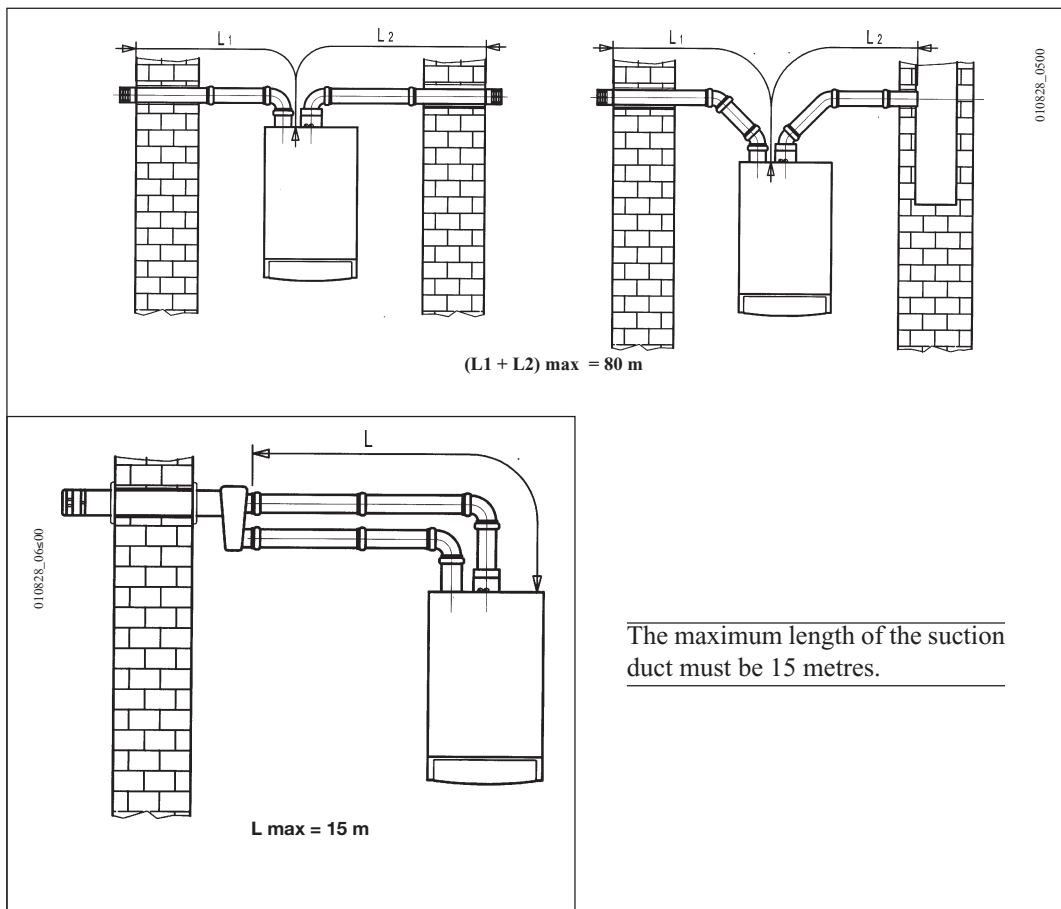

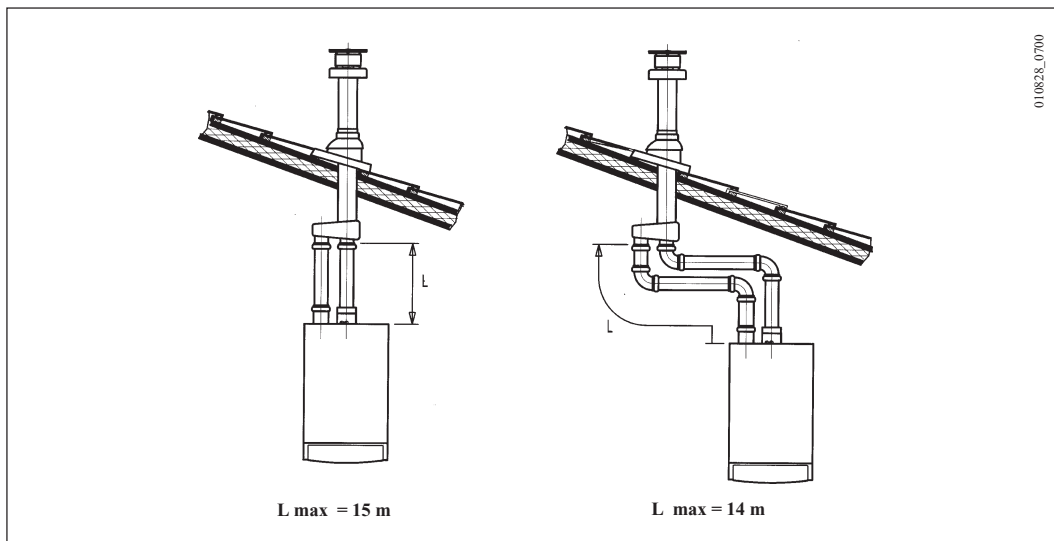

Important: if fitting a single exhaust flue duct, ensure it is adequately insulated (e.g.: with glass wool) wherever the duct passes through building walls.
 For detailed instructions concerning the installation of fittings refer to the technical data accompanying the fittings.

15. Connecting the mains supply Electrical safety of the appliance is only guaranteed by correct grounding, in compliance with the applicable laws and regulations.

Connect the boiler to a 220-230V monophase + ground power supply by means of the three-pin cable supplied with it and make sure you connect polarities correctly.

Use a double-pole switch with a contact separation of at least 3mm in both poles.

In case you replace the power supply cable fit a HAR H05 VV-F' 3x0.75mm² cable with an 8mm diameter max.

The fuse, a fast-acting type rated 2A, is incorporated into the power supply terminals (remove the black fuse holder to enable inspection and/or replacement).

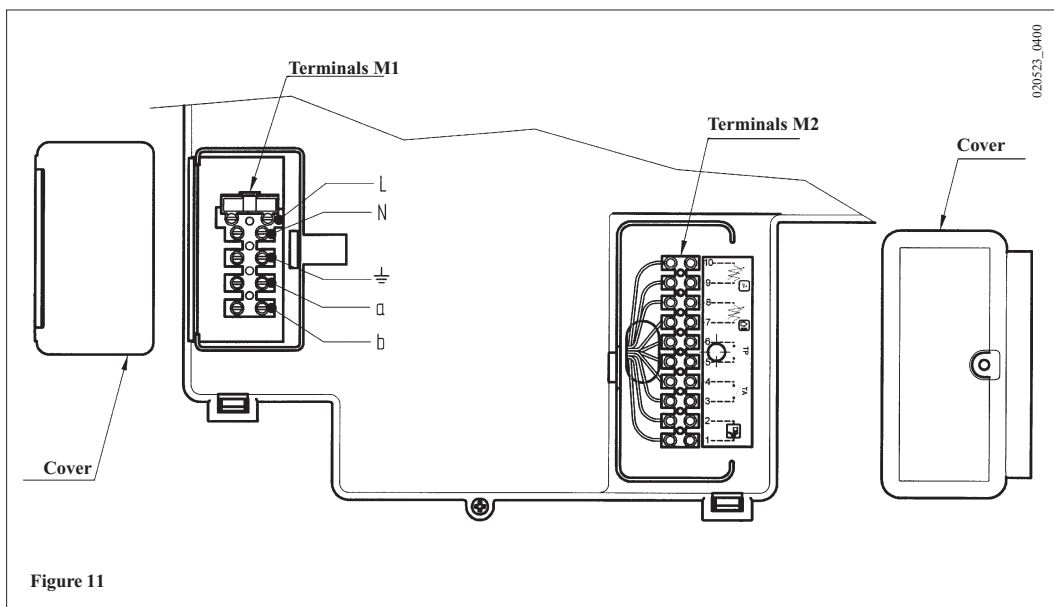

Figure 11

15.1 Description of the electrical connections to the boiler

Turn the control box downward to access terminal boards M1 and M2 used for the electrical connections by removing the two protective covers (see figure 11).

Terminals 1-2: connection of SIEMENS model QAA73 temperature regulator supplied as accessory. Connection polarity is irrelevant.

The jumper fitted across the “TA” terminals 3-4 must be removed.

Read the instructions supplied with this accessory for correct installation and programming procedures.

Terminals 3-4: “TA”, room temperature thermostat connection. Thermostats with integral accelerator resistor must not be used. Check that there is no voltage across the ends of the two thermostat connection wires.

Terminals 5-6: “TP” floor temperature thermostat connection (commercially available device). Check that there is no voltage across the ends of the two thermostat connection wires.

Terminals 7-8: connection of SIEMENS model QAC34 outdoor temperature probe supplied as accessory..

Read the instructions supplied with this accessory for correct installation procedures.

Terminals 9-10: connection of domestic hot water precedence temperature sensor supplied as accessory for connecting heating-only boilers to an external water heater.

Terminals a-b (230V): electricity supply for a zone valve / pump

See instructions in the “connecting a zone system” section.

15.2 Connecting the QAA73 temperature regulator.

The SIEMENS model QAA73 temperature regulator (optional accessory) must be connected to terminals 1-2 of terminal board M2 in figure 11.

The jumper across terminals 3-4, provided for connection of a room temperature thermostat, must be removed.

The settings of the domestic hot water temperature and domestic hot water production schedule must be made using this device.

The timed program of the central heating circuit must be set on the QAA73 if there is a single zone, or in relation to the zone controlled by the QAA73 device.

The timed program for the central heating circuit of the other zones can be set directly on the boiler control panel.

See the instructions provided with the QAA73 temperature regulator for the user parameter programming procedure.

IMPORTANT: For systems divided into zones, parameter 80 “HC2 gradient”, which can be set on the QAA73 temperature regulator, must be set as __ . __ “**not active**”.

QAA73: parameters the installer can set (service)

By pressing the two PROG buttons together for at least three seconds it is possible to access the list of parameters that the installer can display and/or set.

Press either of these buttons to change the parameter to display or change.

Press the [+] or [-] key to change the value displayed.

Press either of the PROG buttons again to save the change.

Press the information button (i) to quit programming.

Here follows a list of the most commonly used parameters:

Line no.	Parameter	Range	Default value
70	HC1 gradient Selection of central heating circuit temperature curve "kt"	2.5...40	15
72	HC1 max. output Central heating system maximum output temperature	25...85	85
74	Type of building	Light, Heavy	Light
75	Room compensation Activation/deactivation of the influence of the room temperature. If it is deactivated, the outdoor temperature sensor must be installed.	on HC1 on HC2 on HC1+HC2 nil	On HC1
77	Automatic adaptation of the temperature curve "kt" in relation to the room temperature.	On - off	On
78	Opt Start Max Maximum time the boiler is switched on ahead of the timed program to optimise the temperature in the premises.	0...360 min	0
79	Opt Stop Max Maximum time the boiler is switched off ahead of the timed program to optimise the temperature in the premises.	0...360 min	0
80	HC2 gradient Selection of temperature curve "kt" of the HC2 central heating circuit of the low temperature zone if the SIEMENS AGU2.500 accessory is used.	2.5...40 —.- = not active	—.-
82	HC2 max. outputMax output temperature of the low temperature central heating system HC2	25...85	70
90	DHW Red Setp Minimum temperature of the domestic domestic hot water	10 or 35...58	10 or 35
91	DHW program Selection of the type of timed program for domestic hot water. 24 h/day = always on PROG HC-1h = as HC1 central heating program less one hour PROG HC = as central heating program PROG ACS = specific domestic hot water program (see also program lines 30-36)	24 h/day TSP HC-1h TSP HC TSP DHW	24 h/day

- fault messages

In the event of fault, the display panel on the QAA73 shows the flashing symbol . Press the information key (i) to display the error code and a description of the fault.

Code	Display	Fault description
10	Outside Sens	External probe sensor fault or parameter 75 has been deactivated
20	Boiler Sensor	NTC delivery sensor fault
50	DHW Sensor	DHW NTC sensor fault
60	Room Sensor	QAA73 fault
110	STL boiler	Safety or flue thermostat tripping
132	Safty Shutwn	Floor thermostat tripping
133	No flame	Gas is low
135	-	No electricity supply to the fan
151	BMU	Error in boiler board. Shut off electric power to boiler for 10 seconds
153	Interlock	The RESET button has been pressed for no reason
160	Fan speed	Fan speed threshold not reached
164	HE Flow/Press	No permissive water differential pressure switch

15.3 Connecting the outdoor temperature sensor probe

The SIEMENS model QAC34 outdoor temperature sensor probe (optional accessory) must be connected to terminals 7-8 of terminal board M2 in figure 11.

The procedures for setting the gradient of the temperature curve “kt” vary depending on the accessories connected to the boiler.

a) Without accessories:

The temperature curve “kt” must be selected by setting parameter H532 as described in section 17 “setting the boiler parameters”.

See graph 1 for selecting the curve referred to a room temperature of 20°C.

The chosen curve can be shifted by pressing the  (2), button (2) on the boiler control panel, and

modifying the value displayed by pressing the  and  keys. See graph 2 for curve selection.

(The example show in graph 2 refers to the curve Kt=15.

Increase the value displayed if the room temperature required is not reached inside the premises for central heating.

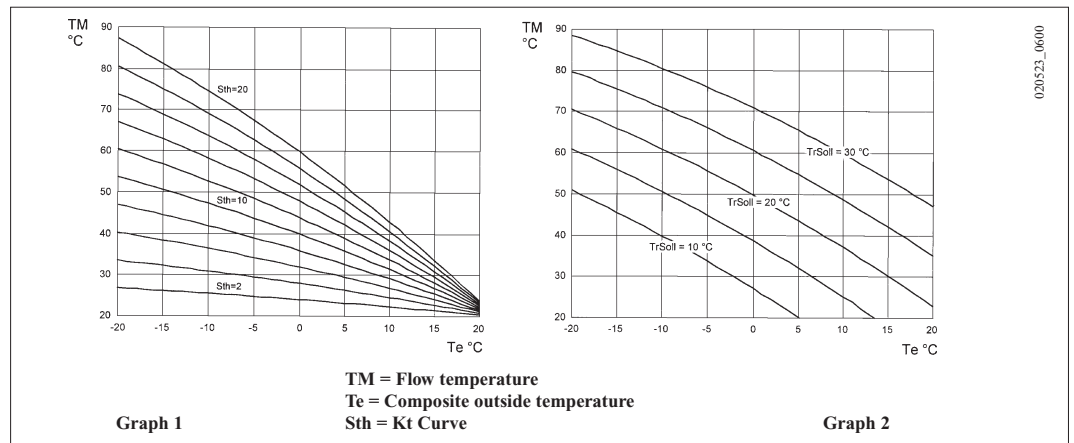

b) with QAA73 temperature regulator:

The temperature curve “kt” must be selected by setting parameter 70 “HC1 gradient” of the QAA73 temperature control device as described in section 15.2 “QAA73: parameters which can be set by the installation (service) engineer”.

See graph 3 for selecting the curve referred to a room temperature of 20°C.

The curve is shifted automatically on the basis of the room temperature set using the QAA73 climate control.

If the system is divided into zones, the temperature curve “kt” relating to the part of the system not controlled by the QAA73 must be selected by setting parameter H532 as described in section 17 “setting the boiler parameters”.

IMPORTANT: For systems divided into zones, parameter 80 “HC2 gradient”, which can be set on the QAA73 temperature regulator, must be set as __ . __ “not active” (see section 15.2).

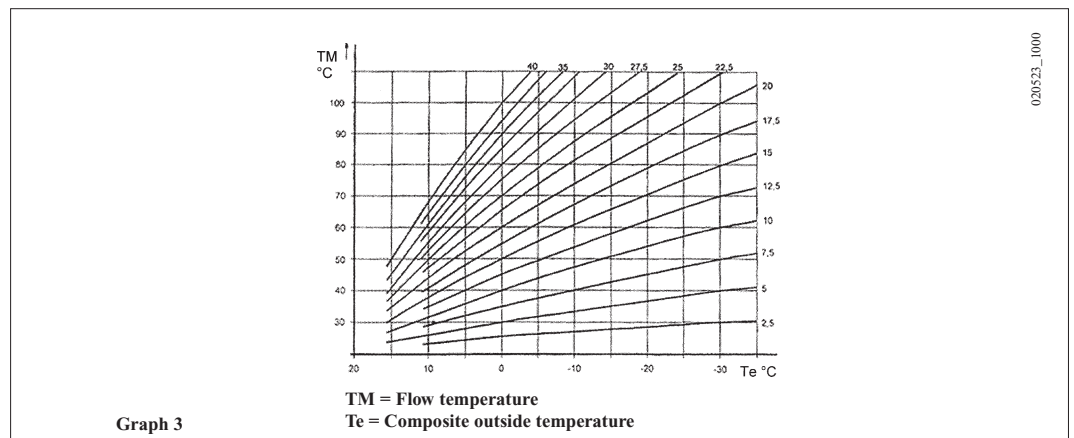

c) with AGU2.500 for control of a low temperature system:

Refer to the instructions provided with the AGU2.500 accessories for connection and control of a low temperature zone.

15.4 Connecting a zoned system

The electrical connection and settings needed to control a system divided into zones vary depending on the accessories connected to the boiler.

a) Without accessories:

The contact relating to the request for operation of the various zones must be parallel-connected and connected to terminal 3-4 “TA” of terminal board M2 in figure 11. The jumper present must be removed.

The central heating temperature is selected directly on the boiler control panel in accordance with the instructions provided for the user in this manual.

b) with QAA73 temperature control device:

The zone valve or pump relating to the room controlled by the QAA73 temperature control device must be supplied with electricity by means of terminals a-b of terminal board M1 in figure 11.

The contact relating to the request for operation of the other zones must be parallel-connected and connected to terminal 3-4 “TA” of terminal board M2 in figure 11. The jumper present must be removed.

The central heating temperature of the zone controlled by the QAA73 is set automatically by the QAA73 itself.

The central heating temperature of the other zones must be selected directly on the boiler control panel.

IMPORTANT: For systems divided into zones, parameter 80 “HC2 gradient”, which can be set on the QAA73 temperature regulator, must be set as __ . . “not active”.

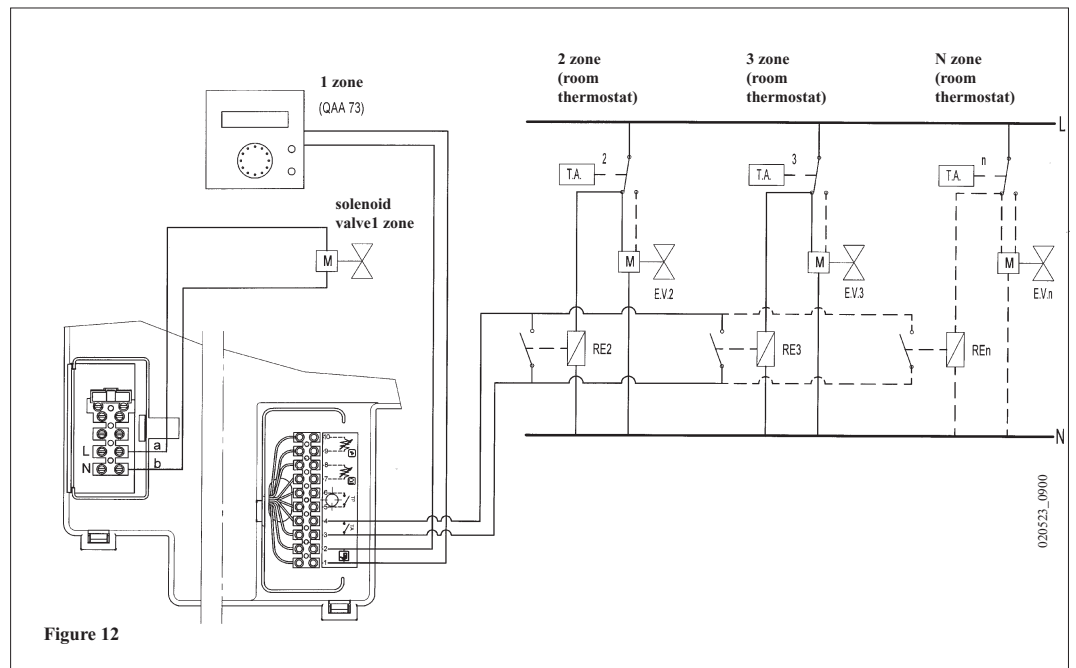

c) with AGU2.500 for control of a low temperature system:

Refer to the instructions provided with the AGU2.500 accessories for connection and control of a low temperature zone.

15.5 Connecting a remote water heater (for LUNA HT 1.120 - 1.240 - 1.280 models)

LUNA HT 1.120 - 1.240 - 1.280 models are designed for connection of a remote water heater since they are fitted in the factory with a motor-operated three-way valve.

Make the water connections to the water heater as shown in figure 13.

Connect the NTC domestic hot water priority probe supplied as an accessory to terminals 9-10 of terminal board M2 in figure 11, first removing the electrical heating element fitted.

The sensor element of the NTC probe must be fitted into the well provided on the water heater.

The domestic hot water temperature can be set and the timed domestic hot water program selected directly on the boiler control panel as described in the instructions provided for the user in this manual.

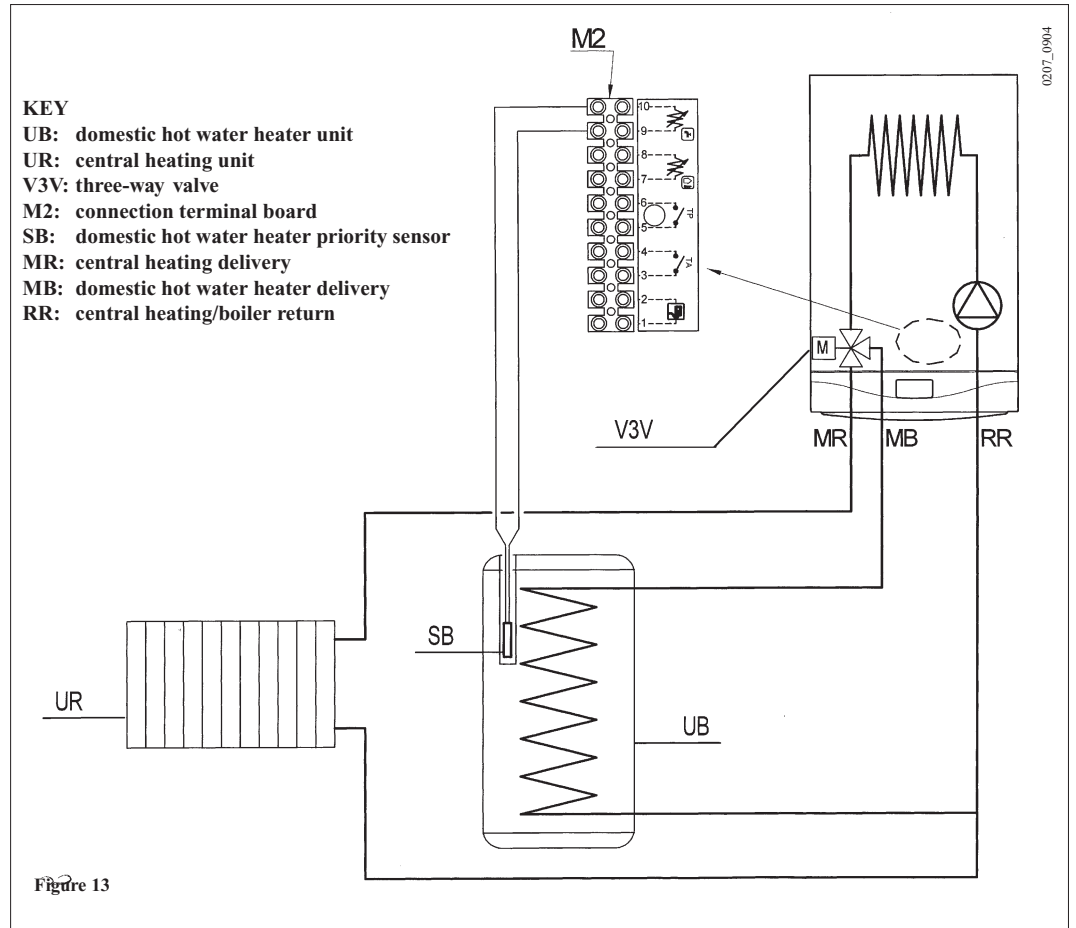

16. Gas change modalities A Qualified Service Engineer may adapt this boiler to operate with natural gas (G20) or with liquid gas (G31).

Carry out the following operations in the given sequence:

- 1) Calibration of the maximum heat output. Check that the CO₂ measured on the flue, with the boiler operating at the maximum heat output, is the same as that shown in table 1. Otherwise, turn the regulation screw (V) on the gas valve. Turn the screw clockwise to increase the concentration of CO₂ and anticlockwise to reduce it.
- 2) Calibration of reduced heat output. Check that the CO₂ measured on the flue, with the boiler operating at the minimum heat output, is the same as that shown in table 1. Otherwise, turn the offset regulation screw (K) on the gas valve. Turn the screw clockwise to increase the concentration of CO₂ and anticlockwise to reduce it.

- Pi: Gas supply pressure connection point
- PO: Gas pressure to burner connection point
- P: Pressure connection point for measurement of the OFFSET
- PI: Air signal input from fan
- V: Gas flow adjuster screw
- K: OFFSET adjuster screw

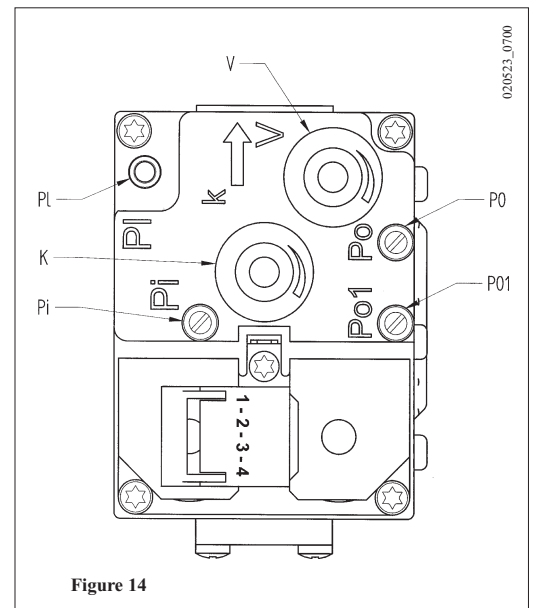

Figure 14

To simplify calibration of the gas valve, the “calibration function” can be set directly on the boiler control panel by proceeding as follows:

- 1) Press the keys (2-3) together until the display shows the pointer “▶” alongside the symbol (about 6 seconds).
- 2) Press the keys to set the fan speed at the minimum and maximum heat output (%PWM);
N.b - to set the **minimum** and **maximum** heat output quickly, press the keys respectively;
- 3) press either of the two keys to exit the function.

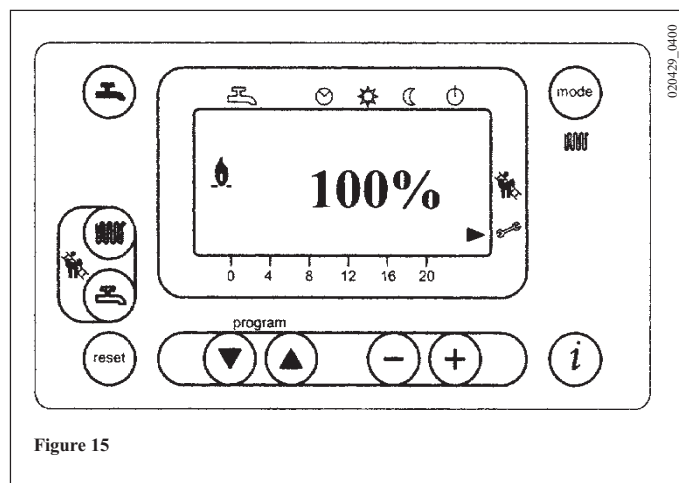

Figure 15

LUNA HT 330 LUNA HT 1.280	G20 - 2H - 20 mbar	G31 - 3P - 37 mbar
CO ₂ max. heat output	8,7% ± 0,2	10% ± 0,2
CO ₂ min. heat output	8,4% ± 0,2	9,8% ± 0,2
Gas nozzle	12,0 mm	12,0 mm

Table 1a

LUNA HT 1.240 LUNA HT 280	G20 - 2H - 20 mbar	G31 - 3P - 37 mbar
CO ₂ max. heat output	8,7% ± 0,2	10% ± 0,2
CO ₂ min. heat output	8,4% ± 0,2	9,5% ± 0,2
Gas nozzle	7,5 mm	7,5 mm

Table 1b

LUNA HT 1.120	G20 - 2H - 20 mbar	G31 - 3P - 37 mbar
CO ₂ max. heat output	8,7% ± 0,2	10% ± 0,2
CO ₂ min. heat output	8,4% ± 0,2	9,5% ± 0,2
Gas nozzle	4,0 mm	4,0 mm

Table 1c

LUNA HT 330		
Gas consumption at 15 °C 1013 mbar	G20 - 2H - 20 mbar	G31 - 3P - 37 mbar
PCI	34.02 MJ/m ³	46.3 MJ/kg
Consumption at max. heat output	3.59 m ³ /h	2.64 kg/h
Consumption at min. heat output	1.06 m ³ /h	0.78 kg/h

Table 2a

LUNA HT 280		
Gas consumption at 15 °C 1013 mbar	G20 - 2H - 20 mbar	G31 - 3P - 37 mbar
PCI	34.02 MJ/m ³	46.3 MJ/kg
Consumption at max. heat output	3.06 m ³ /h	2.25 kg/h
Consumption at min. heat output	0,95 m ³ /h	0.70 kg/h

Table 2b

LUNA HT 1.280		
Gas consumption at 15 °C 1013 mbar	G20 - 2H - 20 mbar	G31 - 3P - 37 mbar
PCI	34.02 MJ/m ³	46.3 MJ/kg
Consumption at max. heat output	3.06 m ³ /h	2.25 kg/h
Consumption at min. heat output	1,06 m ³ /h	0.78 kg/h

Table 2c

LUNA HT 1.240		
Gas consumption at 15 °C 1013 mbar	G20 - 2H - 20 mbar	G31 - 3P - 37 mbar
PCI	34.02 MJ/m ³	46.3 MJ/kg
Consumption at max. heat output	2.61 m ³ /h	1.92 kg/h
Consumption at min. heat output	0.74 m ³ /h	0.54 kg/h

Table 2d

LUNA HT 1.120		
Gas consumption at 15 °C 1013 mbar	G20 - 2H - 20 mbar	G31 - 3P - 37 mbar
PCI	34.02 MJ/m ³	46.3 MJ/kg
Consumption at max. heat output	1.31 m ³ /h	0.96 kg/h
Consumption at min. heat output	0,42 m ³ /h	0,31 kg/h

Table 2e

17. Setting the boiler parameters The boiler parameters may only be modified by professionally qualified staff proceeding as follows:

- a) press the \blacktriangledown \blacktriangle keys on the boiler's front panel together for about 3 s until the parameter H90 appears on the display;
- b) press the \blacktriangledown \blacktriangle keys to select the parameter for modification;
- c) press the \ominus and \oplus keys to modify the parameter;
- d) press the ⓘ key to exit the programming function.
- e) when programming is finished, warning message E183 will blink for 3 seconds approx.
If the warning continues to blink or if other warnings are displayed, press the reset button
When warning message E153 appears, press the reset button a second time.

The following are the parameters generally used:

Parameter N.	Description	Factory setting
H505	Maximum temperature (°C) of the central heating circuit HC1 corresponding to: - the main circuit in systems with just one zone; - the circuit of the zone where the QAA73 temperature control device is installed in case of systems with more than one high-temperature zone; - the high temperature zone circuit in mixed systems and if the SIEMENS AGU2.500 accessory is used.	80
H507	Maximum temperature (°C) of the central heating circuit HC2 of a system with more than one zone, corresponding to the circuit of the low-temperature zone if the SIEMENS AGU2.500 accessory is used.	70
H516	Automatic Summer / Winter switching temperature (°C).	20
H532	Selection of temperature curve of central heating circuit HC1 (see Graph 1)	15
H533	Selection of temperature curve of central heating circuit HC2 (see Graph 1)	15
H536	Selection of central heating power (N. of fan rpm)	See table 3
H544	Pump post-circulation time in central heating mode (min)	3
H545	Burner operating pause time between two start-ups (s)	180
H552	Hydraulic system setting (see instructions provided with the SIEMENS AGU2.500 accessory)	See table 3
H584	Pump / three-way valve anti-blocking operating time (s)	10
H602	Heat exchanger preheating holding time after operation in domestic hot water mode (min)	0
H603	Heat exchanger preheating holding time after operation in central heating mode (min)	0
H615	Programmable function: - "0" electricity supply to zone pump / valve and use of the SIEMENS AGU2.500 accessory; - "1" electricity supply to a remote LPG gas valve; - "5" electricity supply to zone pump / valve in the absence of the SIEMENS AGU2.500 accessory. Only one of these functions can be selected.	5

Parameter N	LUNA HT 280	LUNA HT 330	LUNA HT 1.120	LUNA HT 1.240	LUNA HT 1.280
H536	4900	4550	5650	5900	4550
H552	38	38	35	35	35

Table 3

If the electronic circuit board is replaced, make sure that the parameters set are those specific to the boiler model, as indicated in the documentation available from the authorised Service Centre.

18. Control and operation devices The boiler has been designed in full compliance with European reference standards and in particular is equipped with the following

- **Overheat thermostat**
Thanks to a sensor placed on the heating flow, this thermostat interrupts the gas flow to the main burner in case the water contained in the primary system has overheated. Under these conditions the boiler locks out and you can only repeat the ignition procedure by pressing the reset button on the boiler after you have remedied the cause of the trip.

It is forbidden to disenable this safety device

- **Flue thermostat**
This device, positioned on the flue inside the boiler, interrupts the flow of gas to the burner if the temperature exceeds 90 °C. After verifying the cause of the trip, press the reset button positioned on the thermostat itself, then press the release button on the boiler.

It is forbidden to disenable this safety device

- **Flame ionization detector**
The flame sensing electrode guarantees safety of operation in case of gas failure or incomplete interlighting of the main burner.
Under such conditions the boiler is blocked.
You must press the reset button on the boiler to restore the normal operating conditions.
- **Hydraulic differential pressure sensor**
This pressure sensor, fitted on the hydraulic assembly, allows the main burner to light provided the pump head is as required and protects the flue-water exchanger from possible lacks of water or blockings of the pump.
- **Supplementary running of the pump**
The electronically-controlled supplementary running of the pump lasts 3 minutes, when the boiler is in the central heating mode, after the burner has switched off due to a room thermostat intervention.
- **Frost protection device**
Boilers electronic management includes a “frost protection” function in the central heating system which operates the burner to reach a heating flow temperature of 30°C when the system heating flow temperature drops below 5 °C.
This function is enabled as long as the boiler is connected to the a.c. power and gas supplies and the pressure in the system is as specified.
- **Pump-blocking prevention**
In case there is no call for heat either from the central heating system or from the DHW system for 24 hours on end the pump will automatically switch on for 10 seconds.
- **3-way antiblocking valve**
If there is no heat demand for a period of 24 hours the 3-way valve switches completely.
This function is enabled if the electrical supply to the boiler is on.
- **Hydraulic safety valve (heating circuit)**
This device is set to 3 bar and is used for the heating circuit

The safety valve should be connected to a siphoned drain. Use as a means of draining the heating circuit is strictly prohibited.

19. Positioning of the ignition and flame sensing electrode

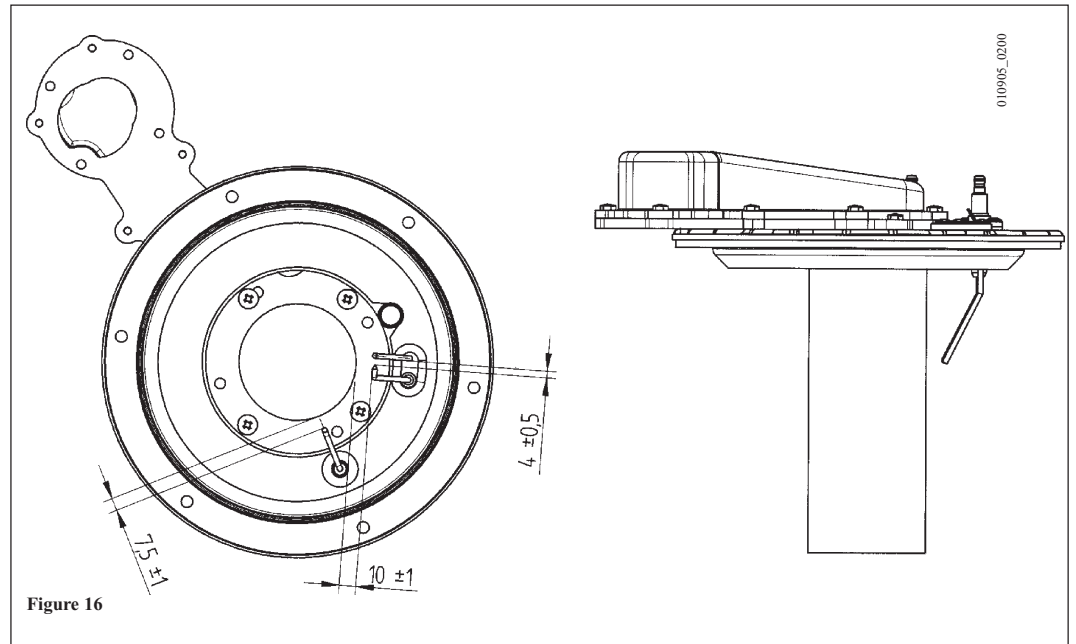

Figure 16

20. Check of combustion parameters To measure combustion performance and hygiene levels of combustion products, the forced draught boiler models are equipped with two test points on the tapered coupling specifically designed for this purpose.

One of the two test points is connected to the exhaust flue duct to allow measurements of the combustion products hygienic standards and combustion efficiency.

The second test point is connected to the comburant air inlet duct to check possible combustion products circulation in case of coaxial ducts.

The exhaust flue duct test point allows measurements of the following:

- combustion products temperature;
- concentration of oxygen (O₂) or, alternatively, of carbon dioxide (CO₂);
- concentration of carbon monoxide (CO).

The comburant air temperature must be measured at the test point connected to the air inlet duct.

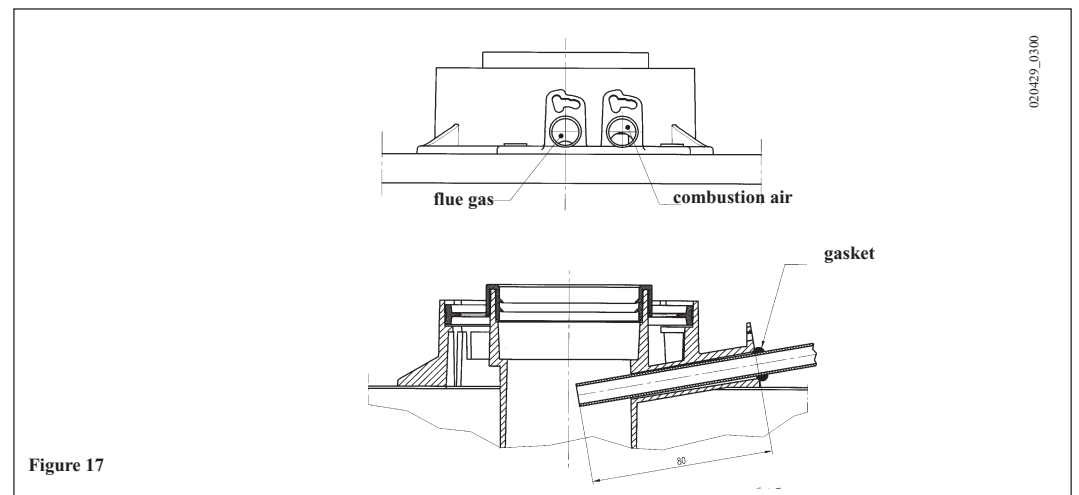

Figure 17

21. Activating the flue-sweeper function To facilitate measurement of the combustion efficiency and improve the cleanliness of the production products, the flue-sweeper function can be activated by proceeding as described below:

- 1) press the (2-3) together until the pointer "▶" appears on the display alongside the symbol (about 3 seconds but no more than 6 seconds). In these conditions, the boiler operates at the maximum heat output set for central heating.
- 2) press either of the buttons to exit the function

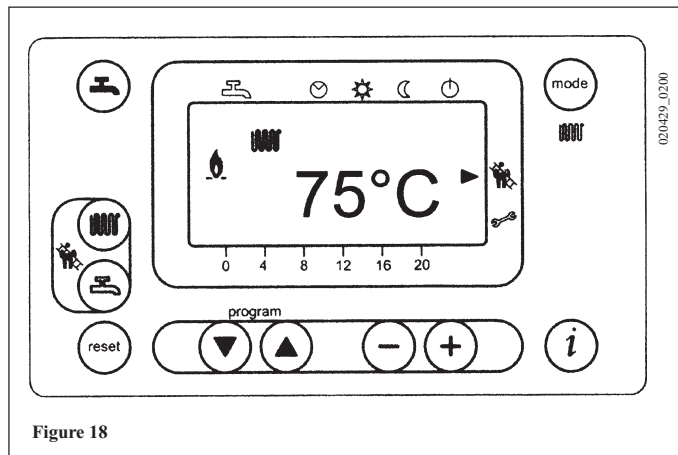
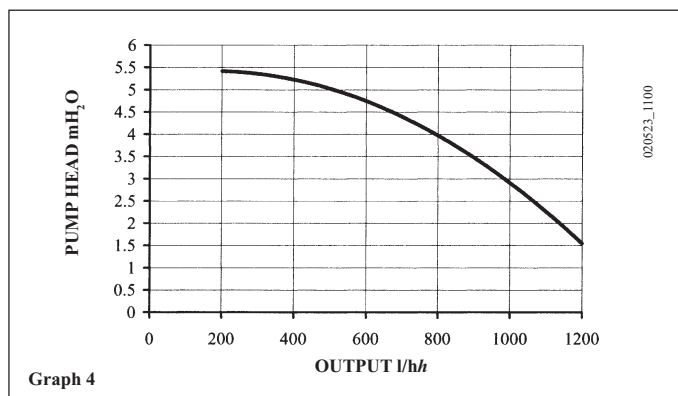

Figure 18

22. Output / pump head performances This is a high static head pump fit for installation on any type of single or double-pipe heating systems. The air vent valve incorporated in the pump allows quick venting of the heating system.



Graph 4

23. How to disassemble the DHW heat exchanger (LUNA HT 280 - HT 330) The stainless steel plate-type DHW heat exchanger is easily disassembled with a screwdriver by operating as described below:

- drain, if possible, only the boiler system, **through the drain tap**;
- drain the DHW system from water;
- remove the circulation pump;
- remove the two screws (right in front of you) securing the DHW heat exchanger and pull it off its seat (Figure 19).

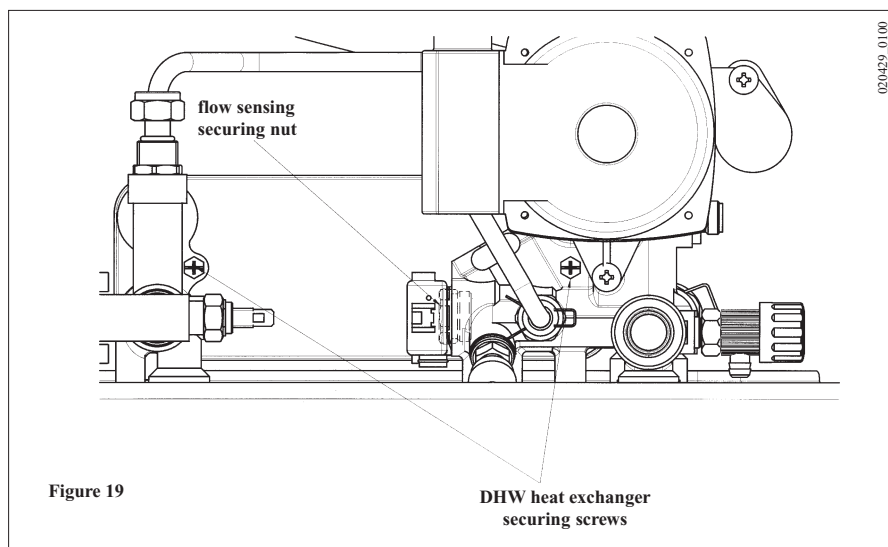

Figure 19

DHW heat exchanger securing screws

To purge the exchanger and/or the DHW system we suggest the use of Cillit FFW-AL or Beckinser HF-AL.

For specific areas where water hardness exceeds 20°F (1°F = 10 mg of calcium carbonate per one litre of water) we recommend you install a polyphosphate metering device - complying with the applicable regulations - in the cold water inlet pipework.

24. Cleaning the cold water filter (LUNA HT 280 - HT 330) The boiler is equipped with a cold water filter placed on the hydraulic assembly. To clean it do the following:

- drain the DHW system from water.
- unscrew the nut on the flow sensing assembly (Figure 19).
- pull out the flow sensing device and its filter.
- remove the impurities.

Important: in the event of replacements and/or cleaning of the O-rings on the hydraulic unit, do not use oil or grease as lubricant but exclusively Molykote 111.

25. Annual service To ensure the boiler operates at peak efficiency, the following checks must be performed every year:

- check on the appearance and tightness of the gas and combustion circuit gaskets;
- check on the condition and position of the ignition and flame sensing electrodes (see section 19);
- check on the condition of the burner and its fixing to the aluminium flange;
- check for any dirt in the combustion chamber. Use a vacuum-cleaner for this cleaning operation,
- check that the gas valve is calibrated correctly (see section 16);
- check if the siphon is dirty;
- check on the central heating system pressure.
- check on the expansion vessel pressure.

**26.1 Boiler schematic
LUNA HT 280 - HT 330**

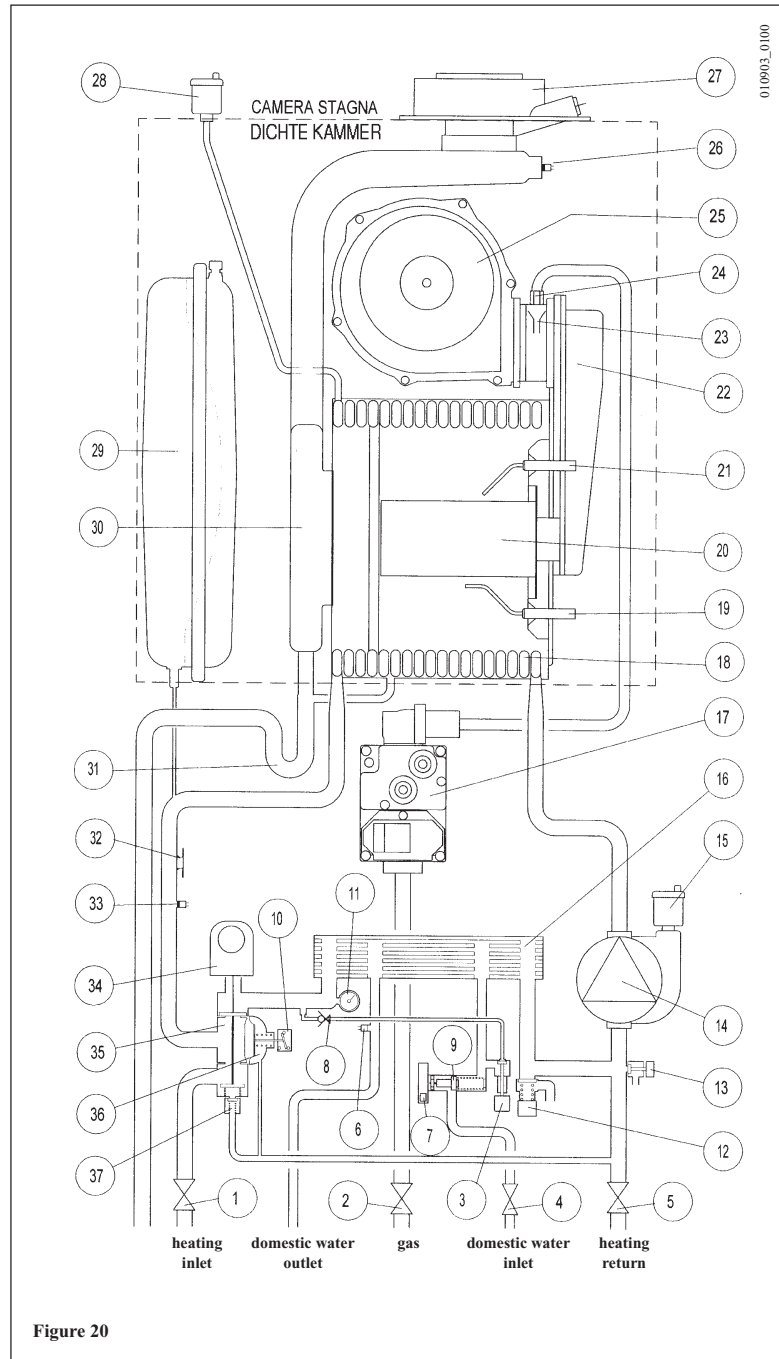

Figure 20

Legenda:

- | | |
|---|---|
| 1 heating delivery cock | 20 main burner |
| 2 gas service cock | 21 ignition electrode |
| 4 boiler filling tap | 22 air/gas mixture header |
| 4 cold water inlet on/off valve and filter | 23 mixer with venturi |
| 5 heating return cock | 24 gas diaphragm |
| 6 DHW NTC sensor / water heater NTC sensor | 25 fan |
| 7 DHW priority sensor | 26 flue thermostat |
| 8 check valve | 27 coaxial fitting |
| 9 flow sensor with filter and water flow rate limiter | 28 automatic air vent |
| 10 hydraulic differential pressure sensor microswitch | 29 expansion vessel |
| 11 manometer | 30 fumes header |
| 12 pressure relief valve | 31 siphon |
| 13 boiler drain point | 32 105°C overheat thermostat |
| 14 pump and air separator | 33 central heating NTC sensor |
| 15 automatic air vent | 34 3-way valve motor |
| 16 plate-type DHW heat exchanger | 35 diverter valve assembly |
| 17 gas valve | 36 hydraulic differential pressure sensor |
| 18 flue-water exchanger | 37 automatic bypass |
| 19 flame detector electrode | |

26.2 Boiler schematic
LUNA HT 1.120 - HT 1.240
HT 1.280

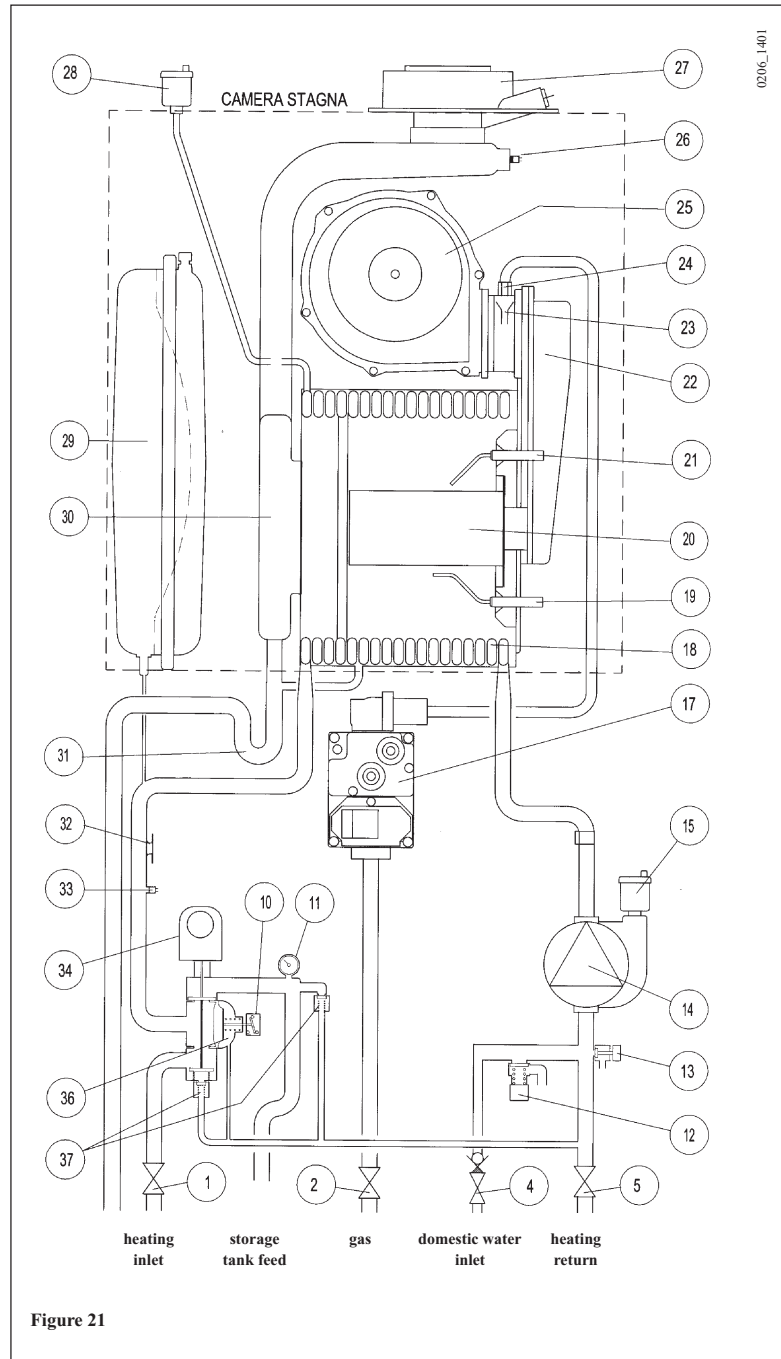
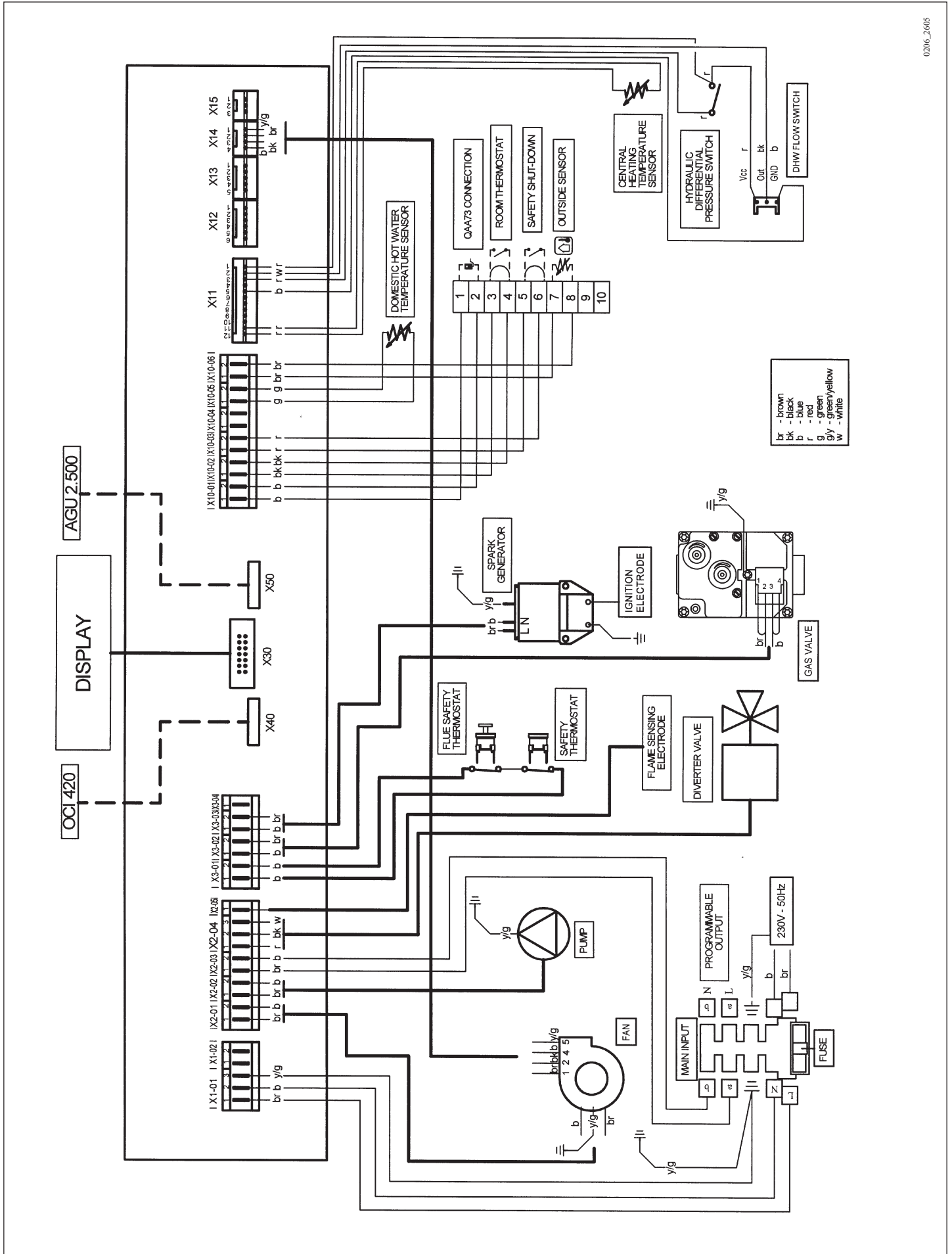

Figure 21

Legenda:

- | | |
|---|---|
| 1 heating delivery cock | 23 mixer with venturi |
| 2 gas service cock | 24 gas diaphragm |
| 4 boiler filling tap | 25 fan |
| 5 heating return cock | 26 flue thermostat |
| 10 hydraulic differential pressure sensor microswitch | 27 coaxial fitting |
| 11 manometer | 28 automatic air vent |
| 12 pressure relief valve | 29 expansion vessel |
| 13 boiler drain point | 30 fumes header |
| 14 pump and air separator | 31 siphon |
| 15 automatic air vent | 32 105°C overheat thermostat |
| 17 gas valve | 33 central heating NTC sensor |
| 18 flue-water exchanger | 34 3-way valve motor |
| 19 flame detector electrode | 35 diverter valve assembly |
| 20 main burner | 36 hydraulic differential pressure sensor |
| 21 ignition electrode | 37 automatic bypass |
| 22 air/gas mixture header | |

27.1 Illustrated wiring diagram
LUNA HT 280 - HT 330



27.2 Illustrated wiring diagram
LUNA HT 1.120 - HT 1.240 - HT 1.280

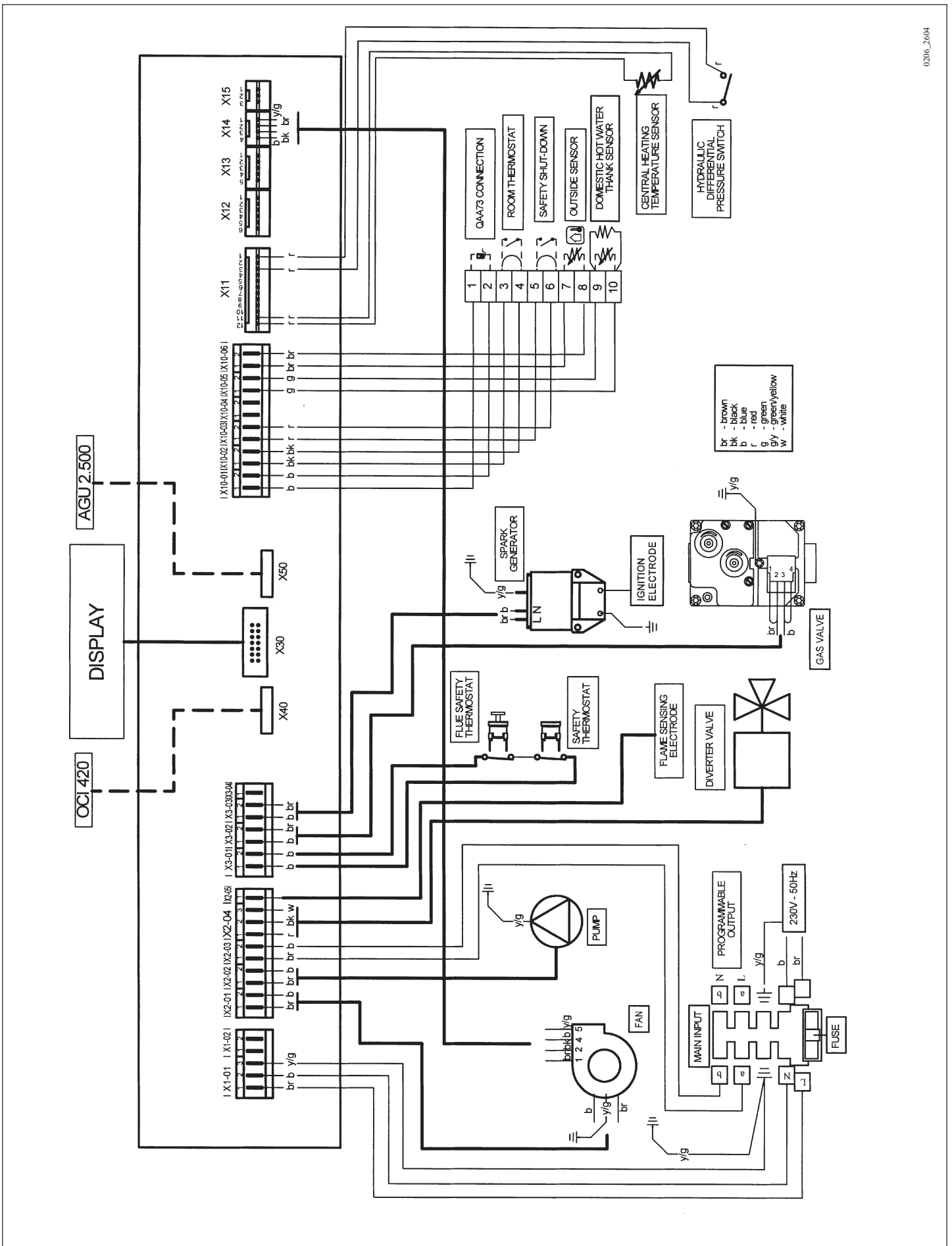

0296_2004

28. Technical data

Boiler model LUNA HT		280	330	1.120	1.240	1.280
Category		II_{2H3P}	II_{2H3P}	II_{2H3P}	II_{2H3P}	II_{2H3P}
DHW rated heat input	kW	28,9	34	-	-	-
CH rated heat input	kW	24,7	28,9	12,4	24,7	28,9
Reduced heat input	kW	9	9,7	4	7	9,7
DHW rated heat output	kW	28	33	-	-	-
	kcal/h	24.080	28.380	-	-	-
CH rated heat output 75/60°C	kW	24	28	12	24	28
	kcal/h	20.640	24.080	10.320	20.640	24.080
CH rated heat output 50/30°C	kW	25,9	30,3	13	25,9	30,3
	kcal/h	22.270	26.060	11.180	22.270	26.060
Rated heat output 75/60°C	kW	8,7	9,4	3,9	6,8	9,4
	kcal/h	7.480	8.090	3.350	5.850	8.090
Rated heat output 50/30°C	kW	9,5	10,2	4,2	7,4	10,2
	kcal/h	8.170	8.770	3.610	6.360	8.770
Central heating system max. pressure	bar	3	3	3	3	3
Expansion vessel capacity	l	10	10	8	8	10
Expansion vessel pressure	bar	0,5	0,5	0,5	0,5	0,5
DHW system max. pressure	bar	8	8	-	-	-
DHW system min. dynamic pressure	bar	0,2	0,2	-	-	-
DHW system min. output	l/min	2,5	2,5	-	-	-
DHW production at ΔT=25 °C	l/min	16,1	18,9	-	-	-
DHW production at ΔT=35 °C	l/min	11,5	13,5	-	-	-
Specific output (*)"D"	l/min	12,9	15,3	-	-	-
Concentric flue duct diameter	mm	60	60	60	60	60
Concentric air duct diameter	mm	100	100	100	100	100
2-pipe flue duct diameter	mm	80	80	80	80	80
2-pipe air duct diameter	mm	80	80	80	80	80
Max. flue mass flow rate	kg/s	0,014	0,016	0,006	0,012	0,014
Min. flue mass flow rate	kg/s	0,004	0,005	0,002	0,003	0,005
Max. flue temperature	°C	75	75	73	73	75
Type of gas used	—	G20	G20	G20	G20	G20
	—	G31	G31	G31	G31	G31
Natural gas feeding pressure	mbar	20	20	20	20	20
Propane gas feeding pressure	mbar	37	37	37	37	37
Power supply voltage	V	230	230	230	230	230
Power supply frequency	Hz	50	50	50	50	50
Rated power supply	W	155	160	145	150	155
Net weight	kg	45,5	46,5	44	45	46
Dimensions	height	mm	763	763	763	763
	width	mm	450	450	450	450
	depth	mm	354	354	354	354
Protection-limit against humidity and water leakages (**)		IPX5D	IPX5D	IPX5D	IPX5D	IPX5D

(*) according to EN 625

(**) according to EN 60529

BAXI s.p.A., in its commitment to constantly improve its products, reserves the right to alter the specifications contained herein at any time and without previous warning.
These Instructions are only meant to provide consumers with use information and under no circumstance should they be construed as a contract with a third party.

BAXI S.p.A.

36061 BASSANO DEL GRAPPA (VI) ITALIA
Via Trozzetti, 20
Tel. 0424 - 517111
Telefax 0424/38089

C603677A